



TECHNISCHE
UNIVERSITÄT
DRESDEN

Faculty of Computer Science Institute for System Architecture, Operating Systems Group

Microkernel-based Operating Systems - Introduction

Carsten Weinhold

Dresden, Oct 09th 2012

- Provide deeper understanding of OS mechanisms
- Illustrate alternative design concepts
- Promote OS research at TU Dresden
- Make you all enthusiastic about OS development in general and microkernels in special

- Lecture every Tuesday, 4:40 PM, INF/E01
- Slides: <http://www.tudos.org> -> Teaching -> Microkernel-based Operating Systems
- Subscribe to our mailing list:
<http://os.inf.tu-dresden.de/mailman/listinfo/mos2012>
- This lecture is not: Microkernel construction (in summer term)

- Exercises (roughly) bi-weekly
Tuesday, 2:50 PM, INF/E01
- Practical exercises in the computer lab
- Paper reading exercises
 - Read a paper beforehand.
 - Sum it up and prepare 3 questions.
 - We expect you to actively participate in discussion.
- First exercise: next week
 - Brinch-Hansen: *Nucleus of a multiprogramming system*

- Complex lab in parallel to lecture
- Build several components of an OS
- “Komplexpraktikum” for (Media) Computer Science students
- “Internship” for Computational Engineering
- Starts in two weeks, 2:50 PM, INF/E01

Date	Lecture	Exercise
Oct 09	Intro	
Oct 16	IPC	Paper: Nucleus of an MP System
Oct 23	Threads & Synchronization	<i>(Complex Lab)</i>
Oct 30	Memory Management	Practical: Booting Fiasco/L4Re
Nov 6	Real-Time	
Nov 13	Device Drivers	Paper: Singularity
Nov 20	Resource Management	<i>(Complex Lab)</i>
Nov 27	Virtualization	Practical: IPC
Dec 4	Legacy Containers	
Dec 11	Security I	Paper: Survey of VM Research
Dec 18	Security II	
Jan 08	Trusted Computing	Practical: L4Linux
Jan 15	Debugging Operating Systems	Paper: <Security>
Jan 22	Faults, Failures & Resilience	<i>(Complex Lab)</i>
Jan 29	Genode ???	

- Manage the available resources
 - Hardware (CPU, memory, ...)
 - Software (file systems, networking stack, ...)
- Provide easier-to-use interface to access resources
 - Unix: read/write data from/to sockets instead of fiddling with TCP/IP packets on your own
- Perform privileged / HW-specific operations
 - x86: ring 0 vs. ring 3
 - Device drivers
- Provide separation and collaboration
 - Isolate users / processes from each other
 - Allow cooperation if needed (e.g., sending messages between processes)

Monolithic kernels: Linux

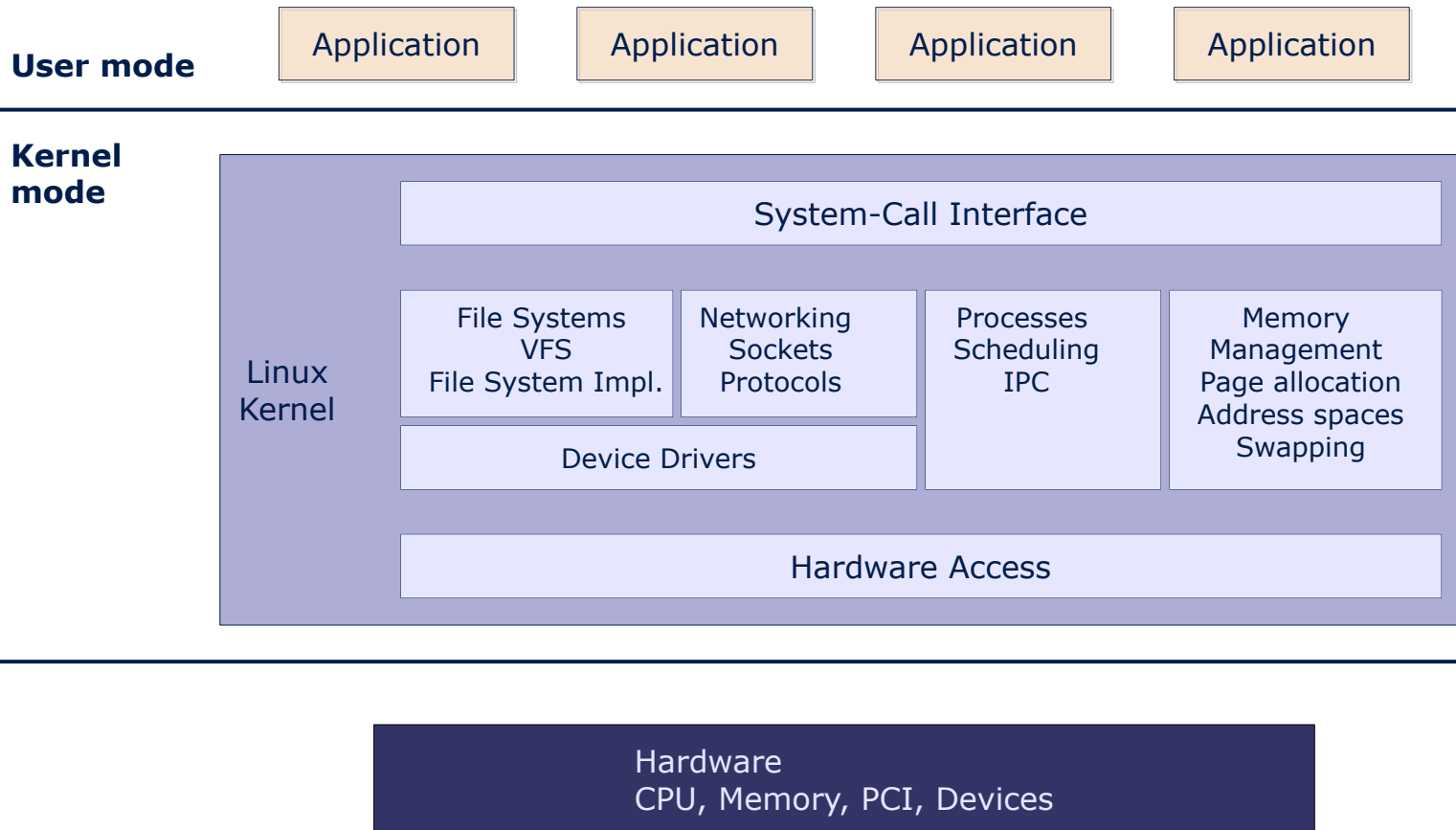

- Security issues
 - All components run in privileged mode.
 - Direct access to all kernel-level data.
 - Module loading → easy living for rootkits.
- Resilience issues
 - Faulty drivers can crash the whole system.
 - 75% of today's OS kernels are drivers.
- Software-level issues
 - Complexity is hard to manage.
 - Custom OS for hardware with scarce resources?

- Minimal OS kernel
 - less error prone
 - small *Trusted Computing Base*
 - suitable for verification
- System services in user-level *servers*
 - flexible and extensible
- Protection between individual components
 - More resilient – crashing component does not (necessarily...) crash the whole system
 - More secure – inter-component protection

The microkernel vision

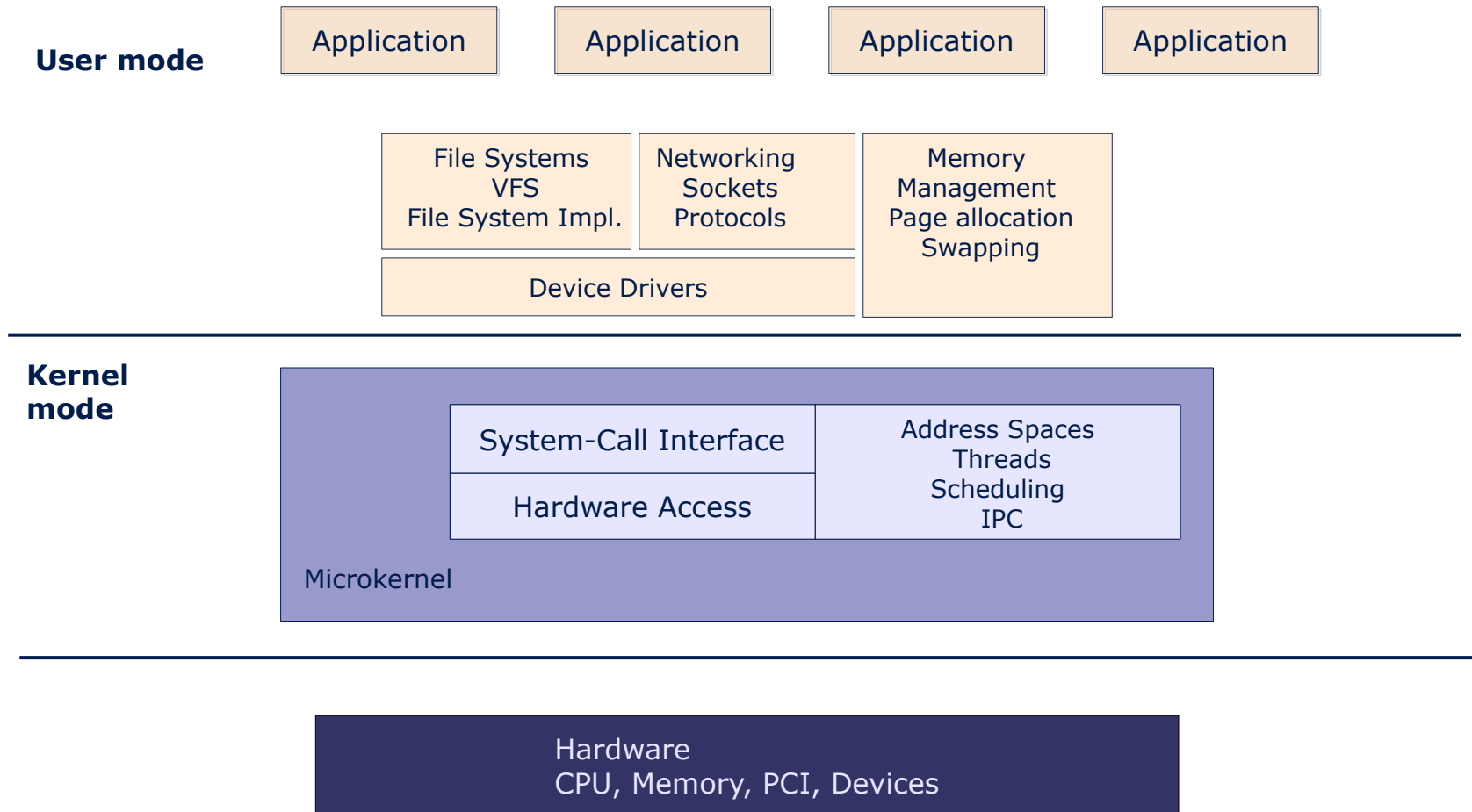

- OS personalities
- Customizability
 - Servers may be configured to suit the target system (small embedded systems, desktop PCs, SMP systems, ...)
 - Remove unneeded servers
- Enforce reasonable system design
 - Well-defined interfaces between components
 - No access to components besides these interfaces
 - Improved maintainability

- Mach – developed at CMU, 1985 - 1994
 - Rick Rashid (today head of MS Research)
 - Avie Tevanian (former Apple CTO)
 - Brian Bershad (professor @ U. of Washington)
 - ...
- Foundation for several real systems
 - Single Server Unix (BSD4.3 on Mach)
 - MkLinux (OSF)
 - IBM Workplace OS
 - NeXT OS → Mac OS X

- Simple, extensible *communication kernel*
 - “Everything is a pipe.” – *ports* as secure communication channels
- Multiprocessor support
- Message passing by mapping
- Multi-server OS personality
- POSIX-compatibility
- Shortcomings
 - performance
 - drivers still in the kernel

- Main goals:

- multiple OS personalities
- run on multiple HW architectures

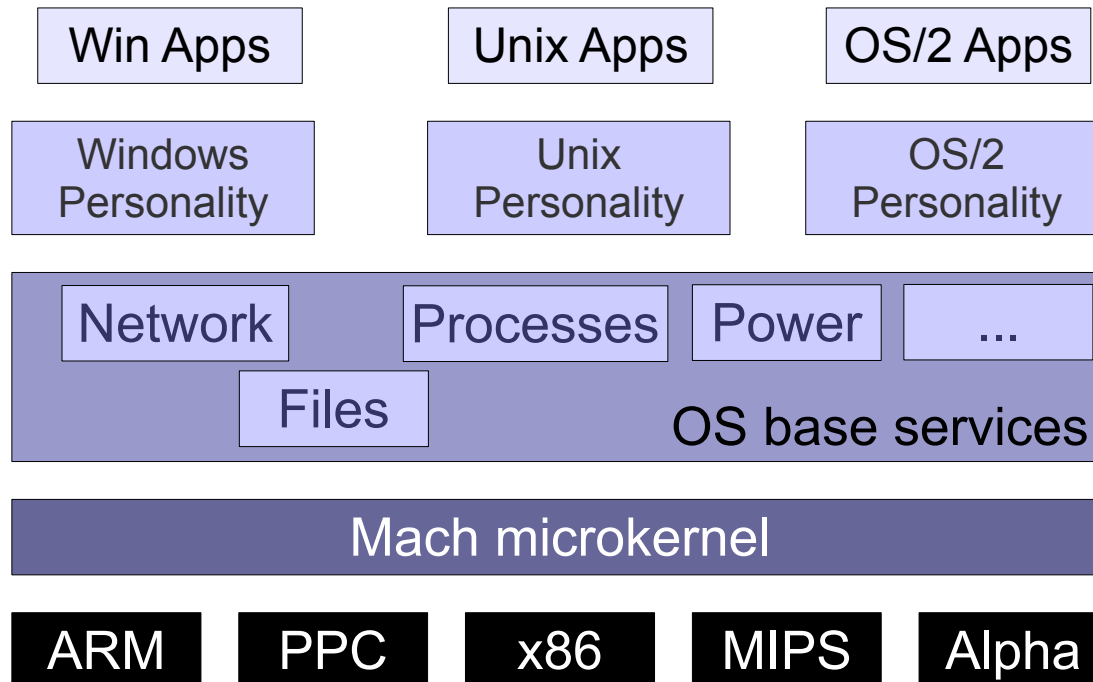

- Never finished (but spent 1 billion \$)
- Failure causes:
 - Underestimated difficulties in creating OS personalities
 - Management errors, forced divisions to adopt new system without having a system
 - “Second System Effect”: too many fancy features
 - Too slow
- Conclusion: Microkernel worked, but system atop the microkernel did not

- OS personalities did not work
- Flexibility – but monolithic kernels became flexible, too (Linux kernel modules)
- Better design – but monolithic kernels also improved (restricted symbol access, layered architectures)
- Maintainability – still very complex
- Performance matters a lot

- Subsystem protection / isolation
- Code size
 - Microkernel-based OS
 - Fiasco kernel: $\sim 34,000$ LoC
 - "HelloWorld" (+boot loader +root task): $\sim 10,000$ LoC
 - Linux kernel (3.0.4., x86 architecture):
 - Kernel: ~ 2.5 million LoC
 - +drivers: ~ 5.4 million LoC
 - (*generated using David A. Wheeler's 'SLOCCount'*)
- Customizability
 - Tailored memory management / scheduling / ... algorithms
 - Adaptable to embedded / real-time / secure / ... systems

- We need fast and efficient kernels
 - covered in the “Microkernel construction” lecture in the summer term
- We need fast and efficient OS services
 - Memory and resource management
 - Synchronization
 - Device Drivers
 - File systems
 - Communication interfaces
 - subject of this lecture

- Minix @ FU Amsterdam (Andrew Tanenbaum)
- Singularity @ MS Research
- EROS/CoyotOS @ Johns Hopkins University
- The L4 Microkernel Family
 - Originally developed by Jochen Liedtke at IBM and GMD
 - 2nd generation microkernel
 - Several kernel ABI versions

The L4 family – a timeline (or tree ...)

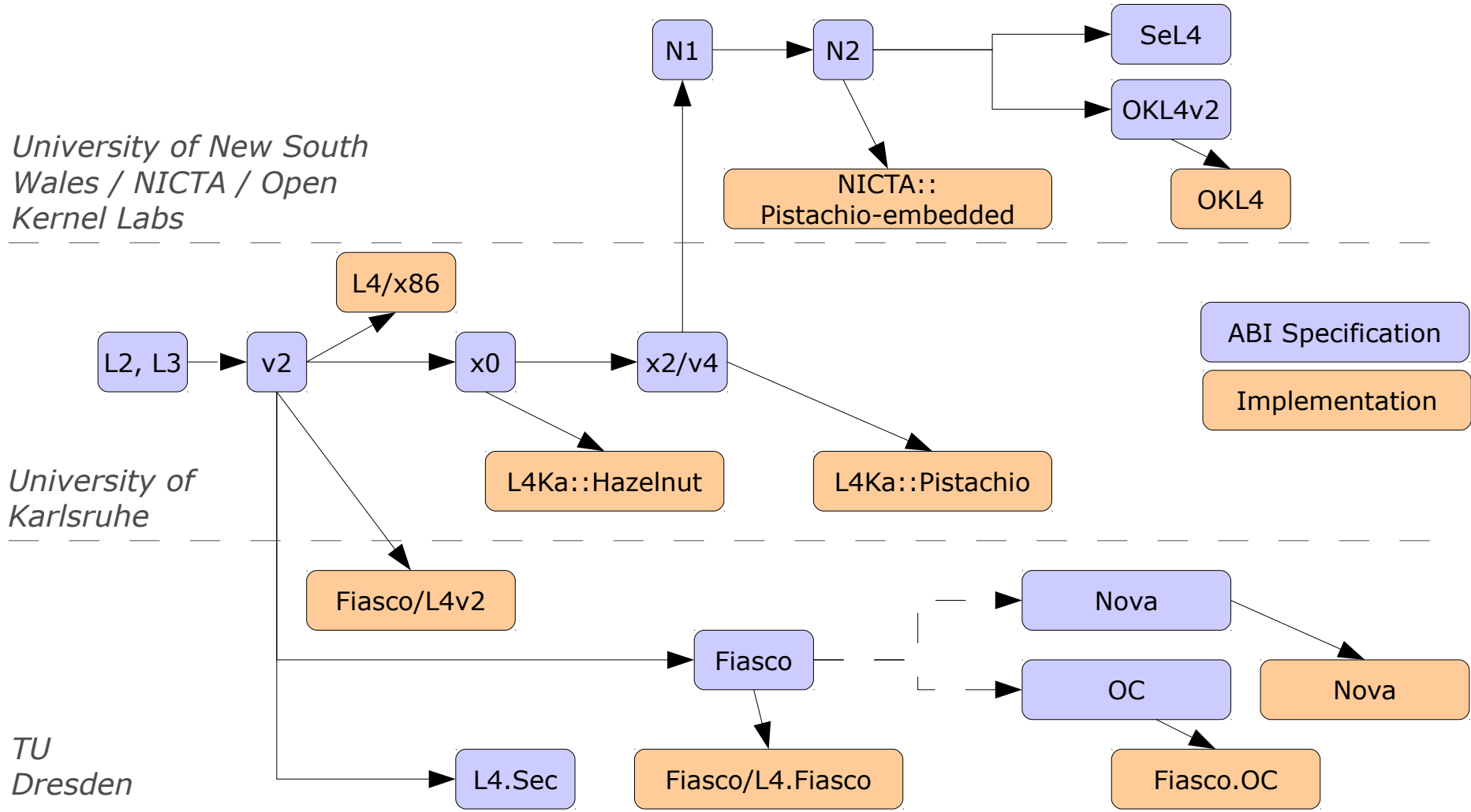

- Jochen Liedtke:
"A microkernel does no real work."
 - Kernel only provides inevitable mechanisms.
 - Kernel does not enforce policies.
- But what **is** inevitable?
 - Abstractions
 - Threads
 - Address spaces (tasks)
 - Mechanisms
 - Communication
 - Resource mapping
 - (Scheduling)

Taking a closer look at L4
Case study: **L4/Fiasco.OC**

- “Everything is an object”
 - Task Address spaces
 - Thread Activities, scheduling
 - IPC Gate Communication, resource mapping
 - IRQ Communication
 - Factory Create other objects, enforce resource quotas
- One system call: **invoke_object()**
 - Parameters passed in UTCB
 - Types of parameters depend on type of object

- Kernel-provided objects
 - Threads
 - Tasks
 - IRQs
 - ...
- Generic communication object: IPC gate
 - Send message from sender to receiver
 - Used to implement **new objects** in **user-level** applications

- Everything above kernel built using user-level objects that provide a service
 - Networking stack
 - File system
 - ...
- Kernel provides
 - Object creation/management
 - Object interaction: Inter-Process Communication (IPC)

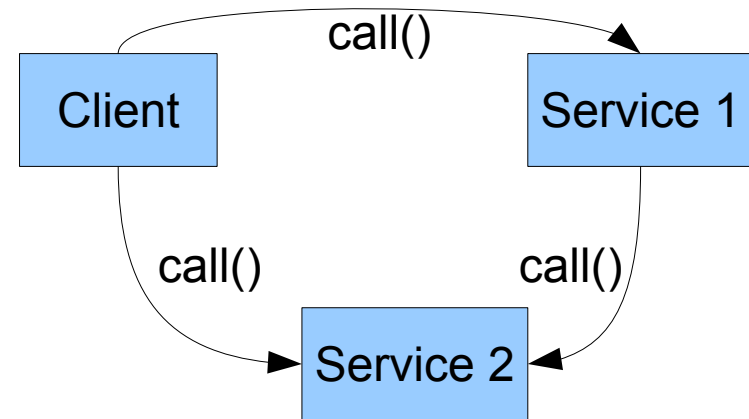

- To call an object, we need an address:
 - Telephone number
 - Postal address
 - IP address
 - ...

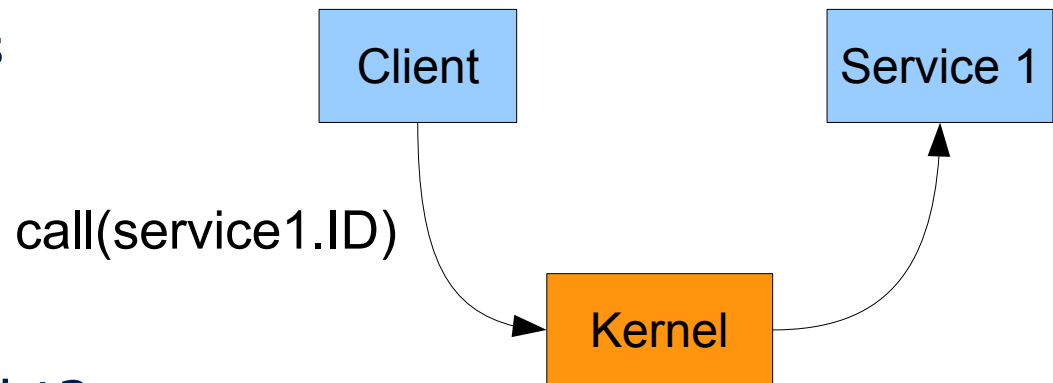

- Simple idea, right?
- ID is wrong? Kernel returns ENOTEXIST
- But not so fast! This scheme is insecure:
 - Client could simply “guess” IDs brute-force.
 - Existence/non-existence can be used as a covert channel

- Global object IDs are
 - insecure (forgery, covert channels).
 - inconvenient (programmer needs to know about partitioning in advance)
- Solution in Fiasco.OC
 - Task-local *capability space* as an indirection
 - *Object capability* required to invoke object
- Per-task name space
 - Maps names to object capabilities.
 - Configured by task's creator

- Capability:
 - Reference to an object
 - Protected by the Fiasco.OC kernel
 - Kernel knows all capability-object mappings.
 - Managed as a per-process capability table.
 - User processes only use indexes into this table.

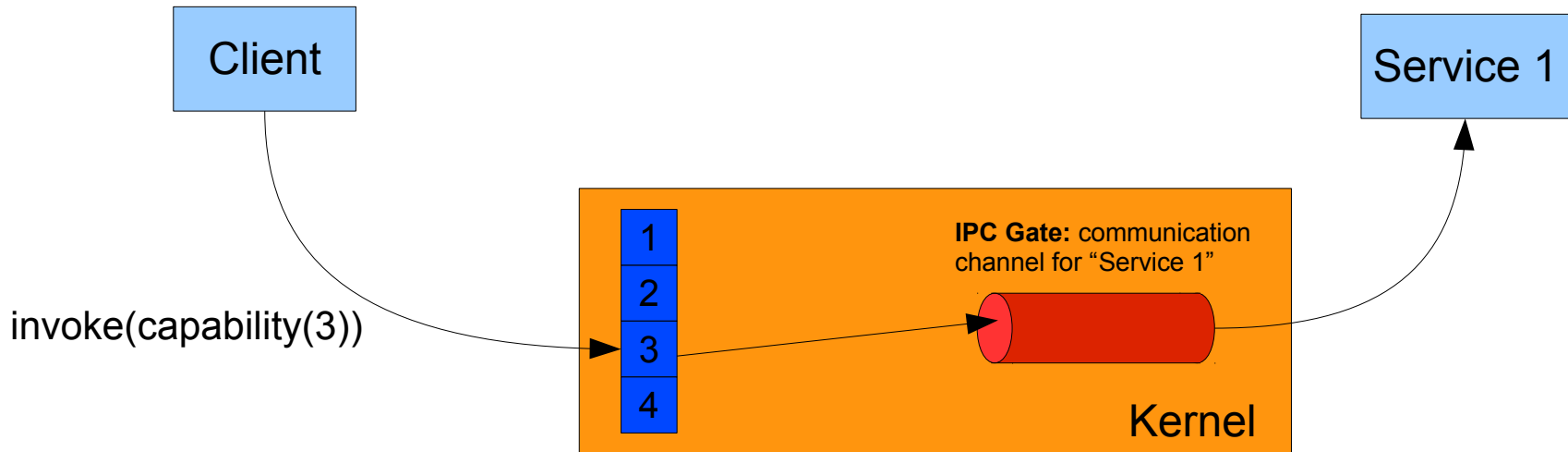

- Kernel object for communication: *IPC gate*
- Inter-process communication (IPC)
 - Between threads
 - Synchronous
- Communication using IPC gate:
 - Sender thread puts message into its UTCB
 - Sender invokes IPC gate, blocks sender until receiver ready (i.e., waits for message)
 - Kernel copies message to receiver thread's UTCB
 - Both continue, knowing that message has been transferred/received

Indirection allows for security and flexibility.

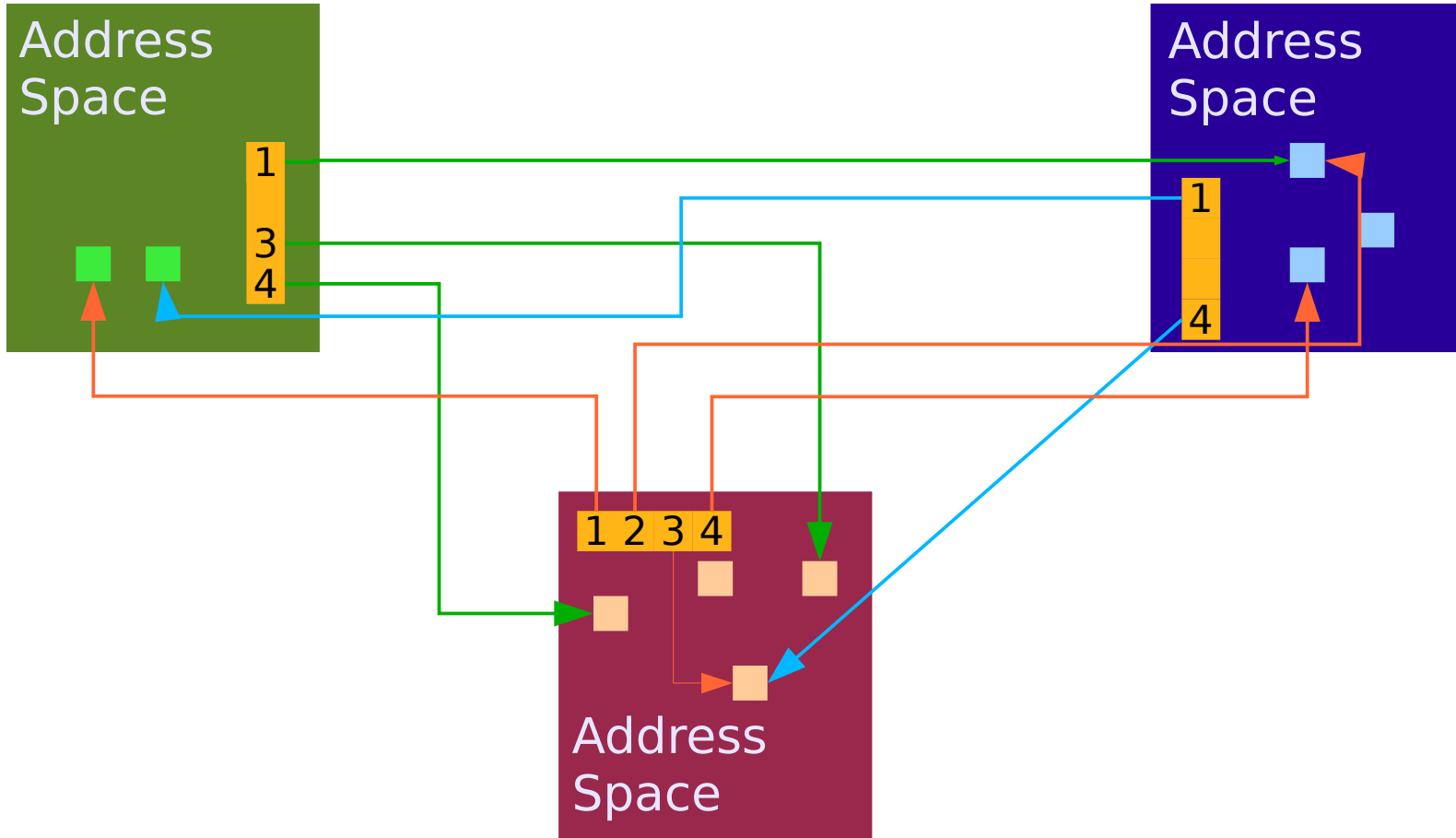



More L4 concepts

- Thread
 - Unit of Execution
 - Implemented as kernel object
- Properties managed by the kernel:
 - Instruction Pointer (EIP)
 - Stack (ESP)
 - Registers
 - User-level TCB
- User-level applications need to
 - allocate stack memory
 - provide memory for application binary
 - find entry point
 - ...

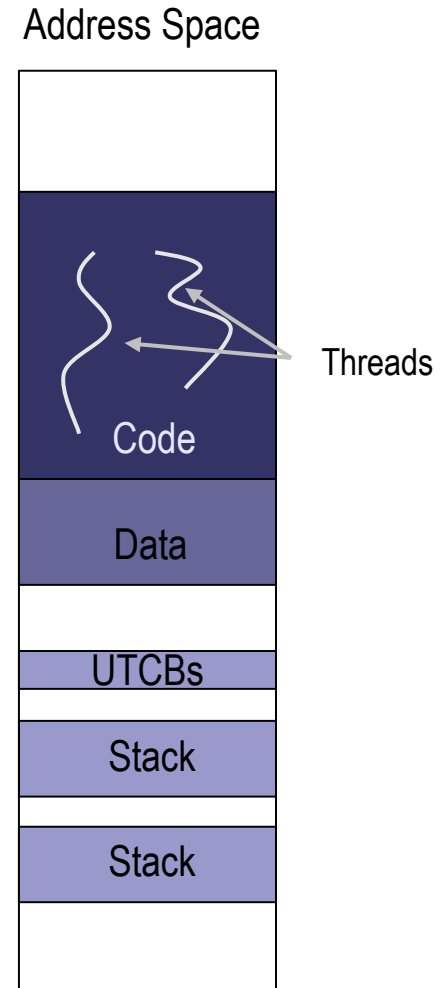

- Kernel object: IRQ
- Used for hardware and software interrupts
- Provides asynchronous signaling
 - `invoke_object(irq_cap, WAIT)`
 - `invoke_object(irq_cap, TRIGGER)`

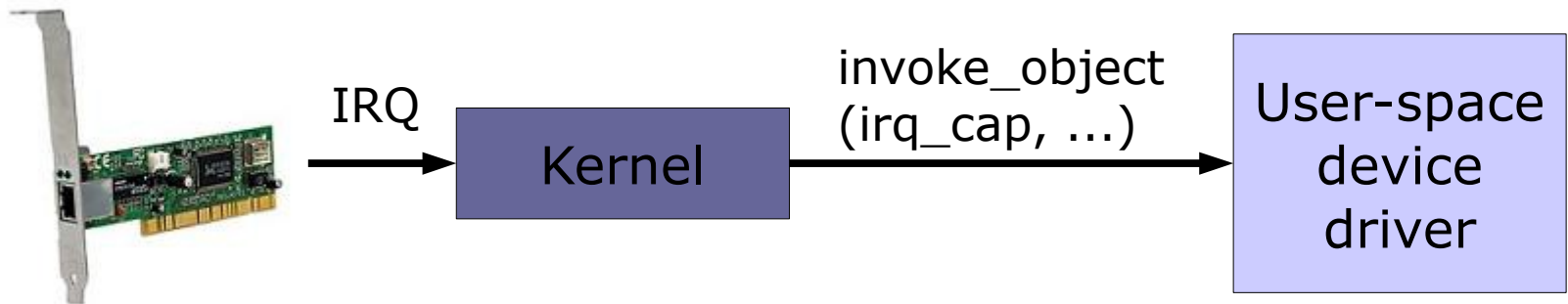

Problem: Memory partitioning

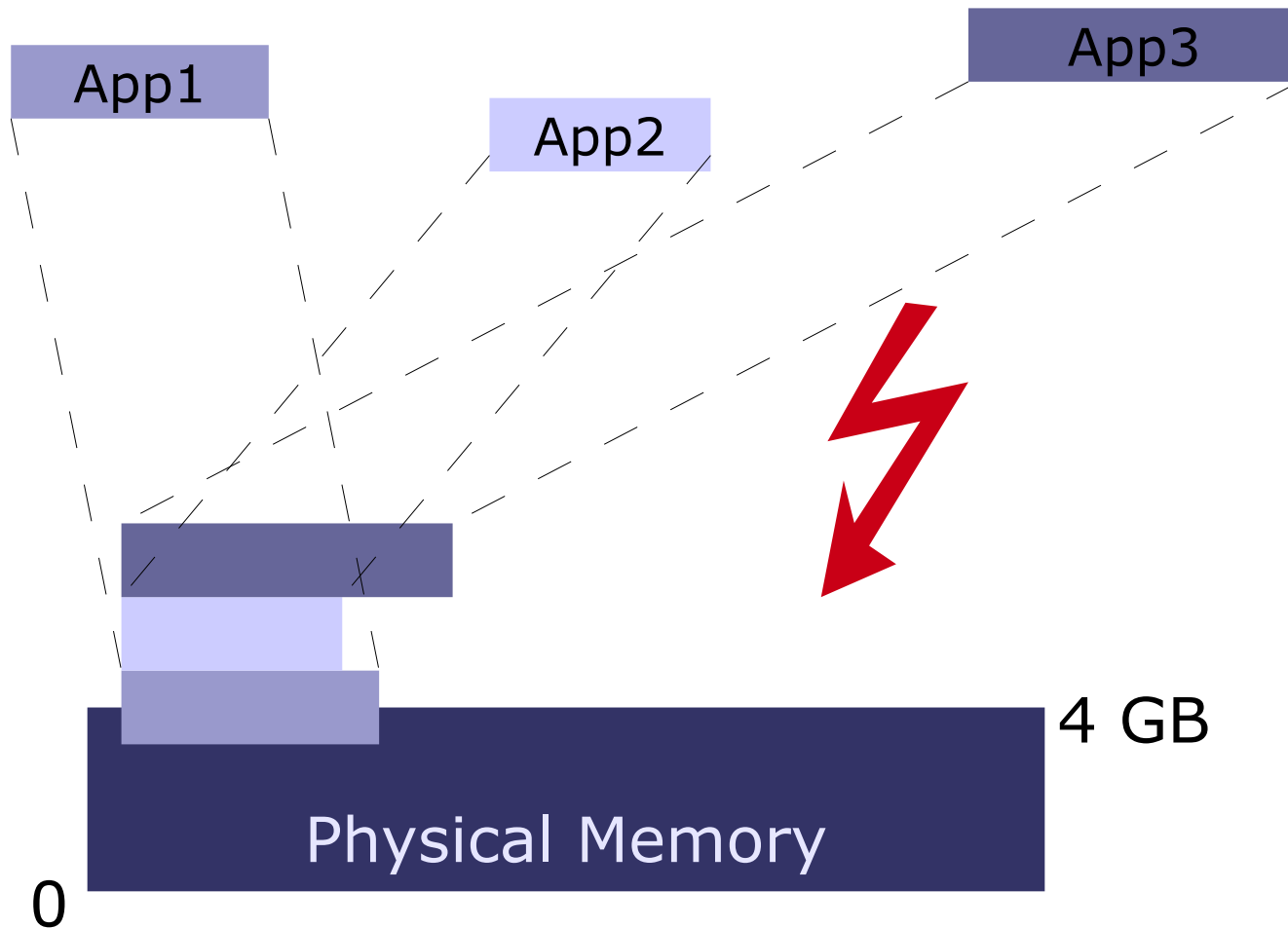

Solution: Virtual Memory

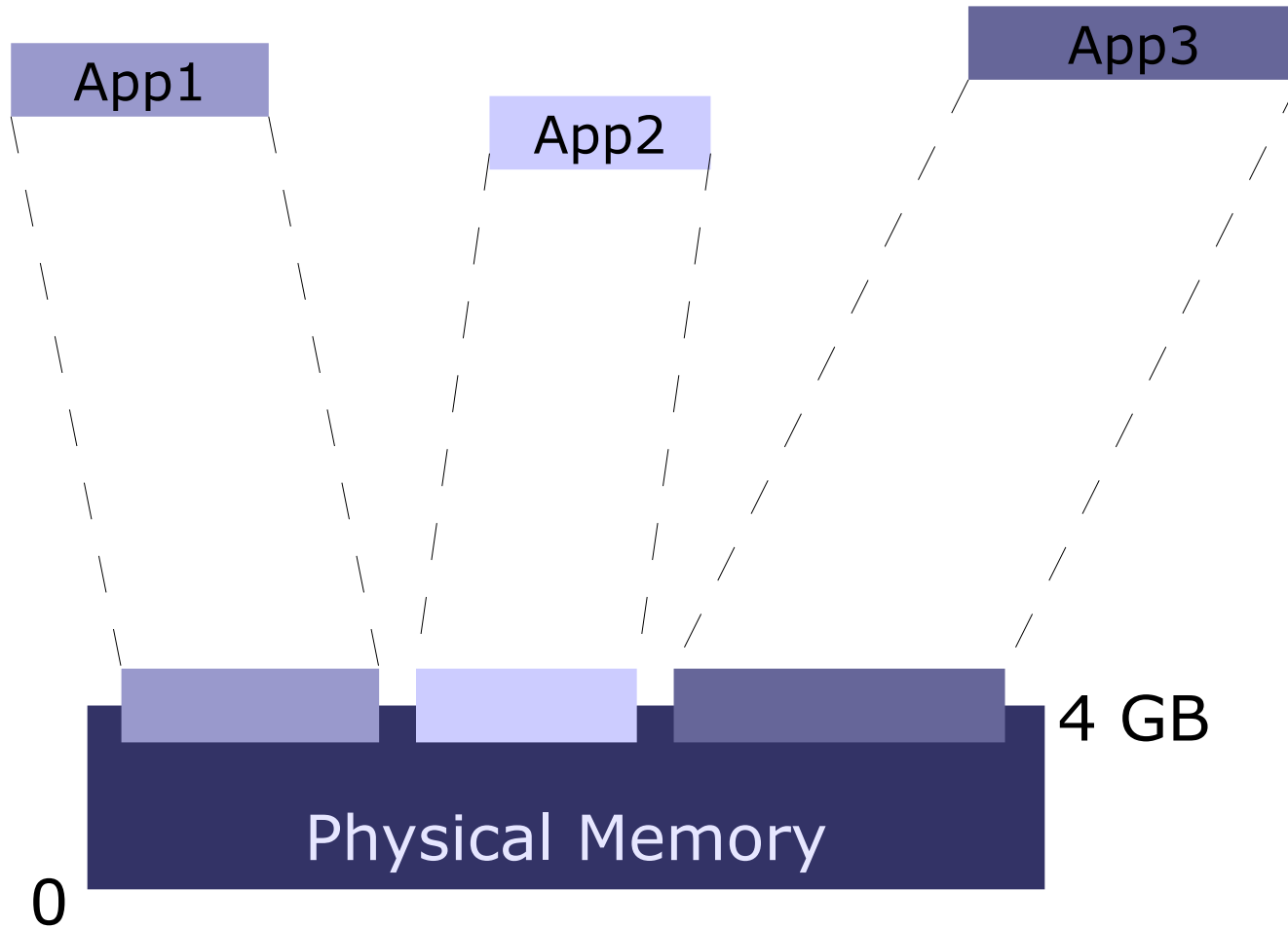

- If a thread has access to a capability, it can map this capability to another thread
- Mapping / not mapping of capabilities used for implementing access control
- Abstraction for mapping: *flexpage*
- Flexpages describe mapping
 - location and size of resource
 - receiver's rights (read-only, mappable)
 - type (memory, I/O, communication capability)

L4: Recursive address spaces

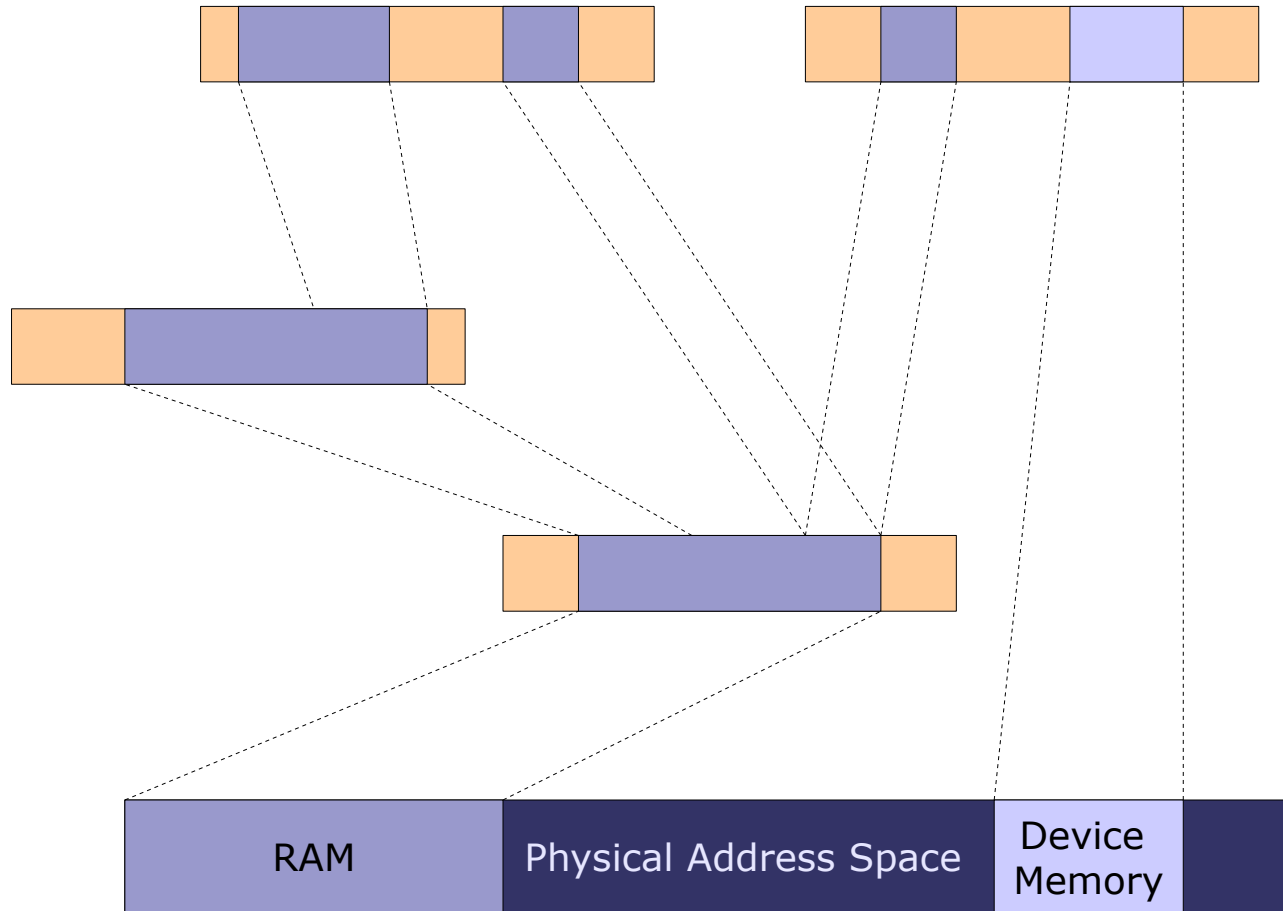

- Summary of object types
 - Task
 - Thread
 - IPC Gate
 - IRQ
 - Factory
- Each task gets initial set of capabilities for some of these objects at startup

What can we build with all this?

- Fiasco.OC is not a full operating system!
 - No device drivers (except UART + timer)
 - No file system / network stack / ...
- A microkernel-based OS needs to add these services as user-level components

L4Re – L4 Runtime Environment

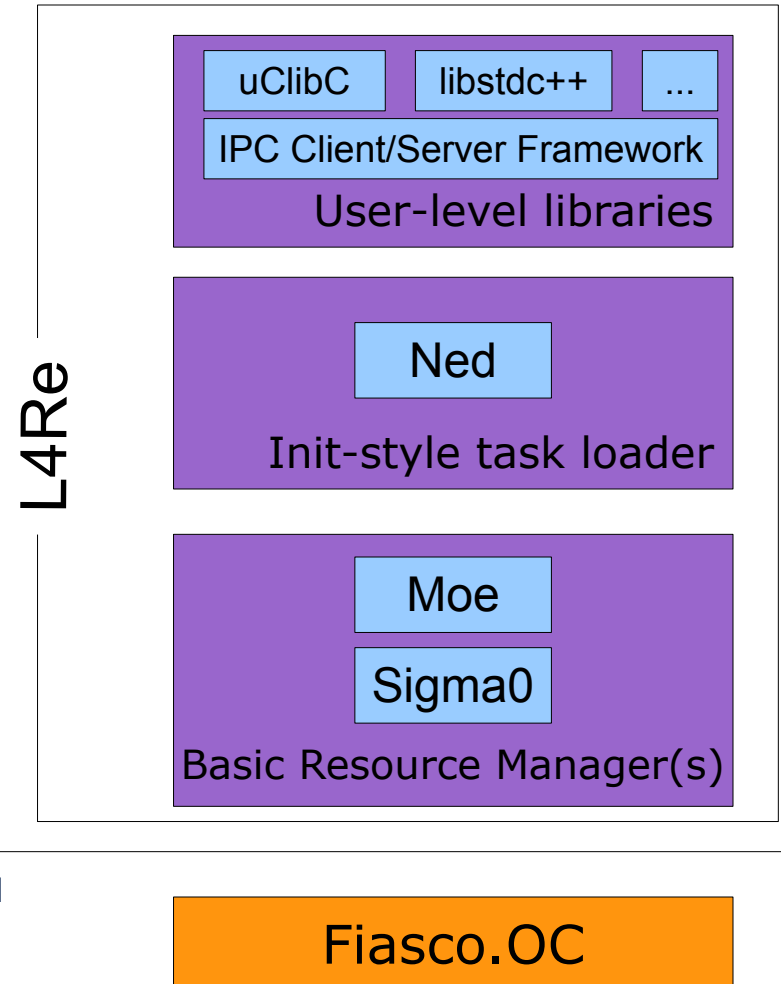

Linux on L4

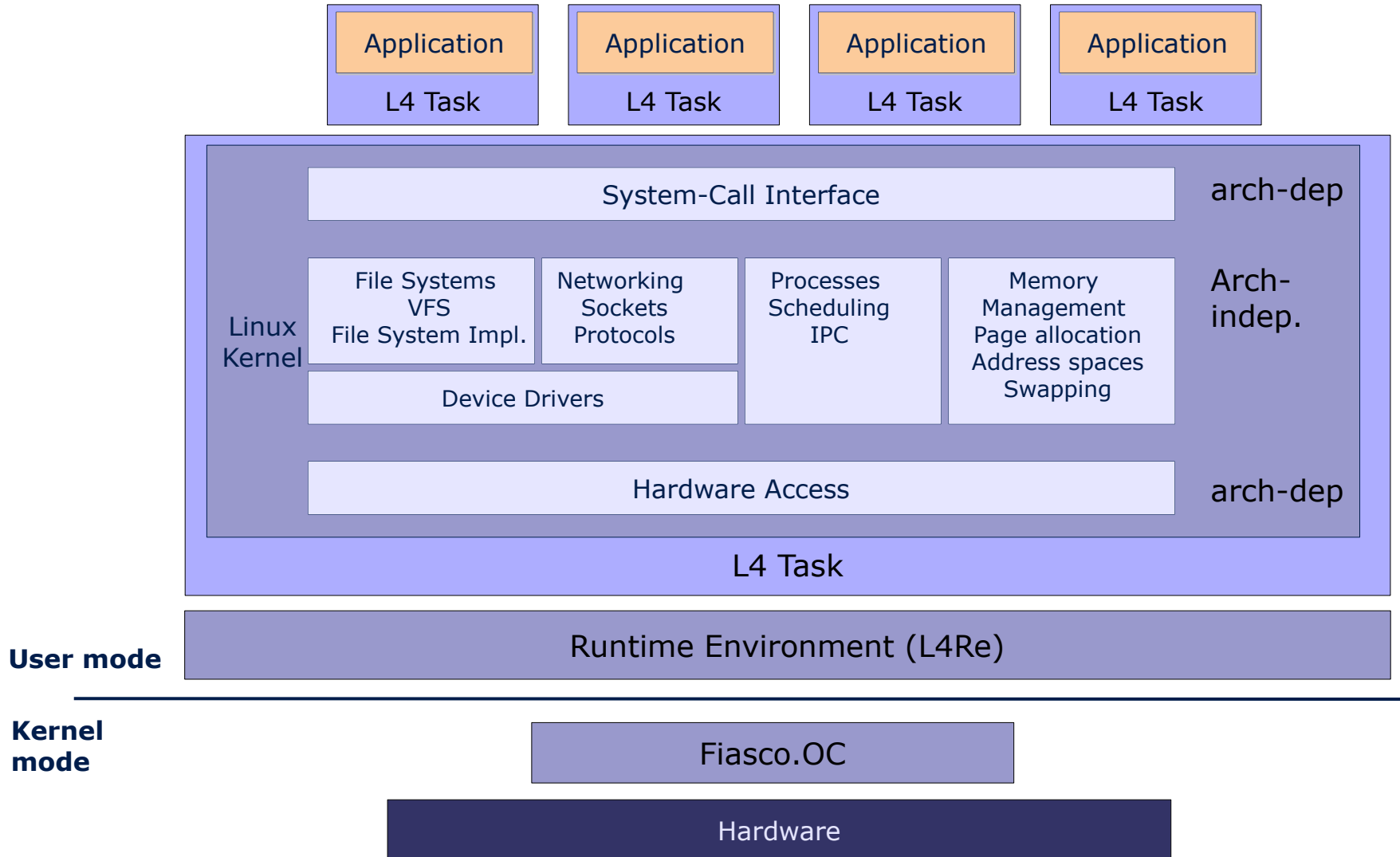

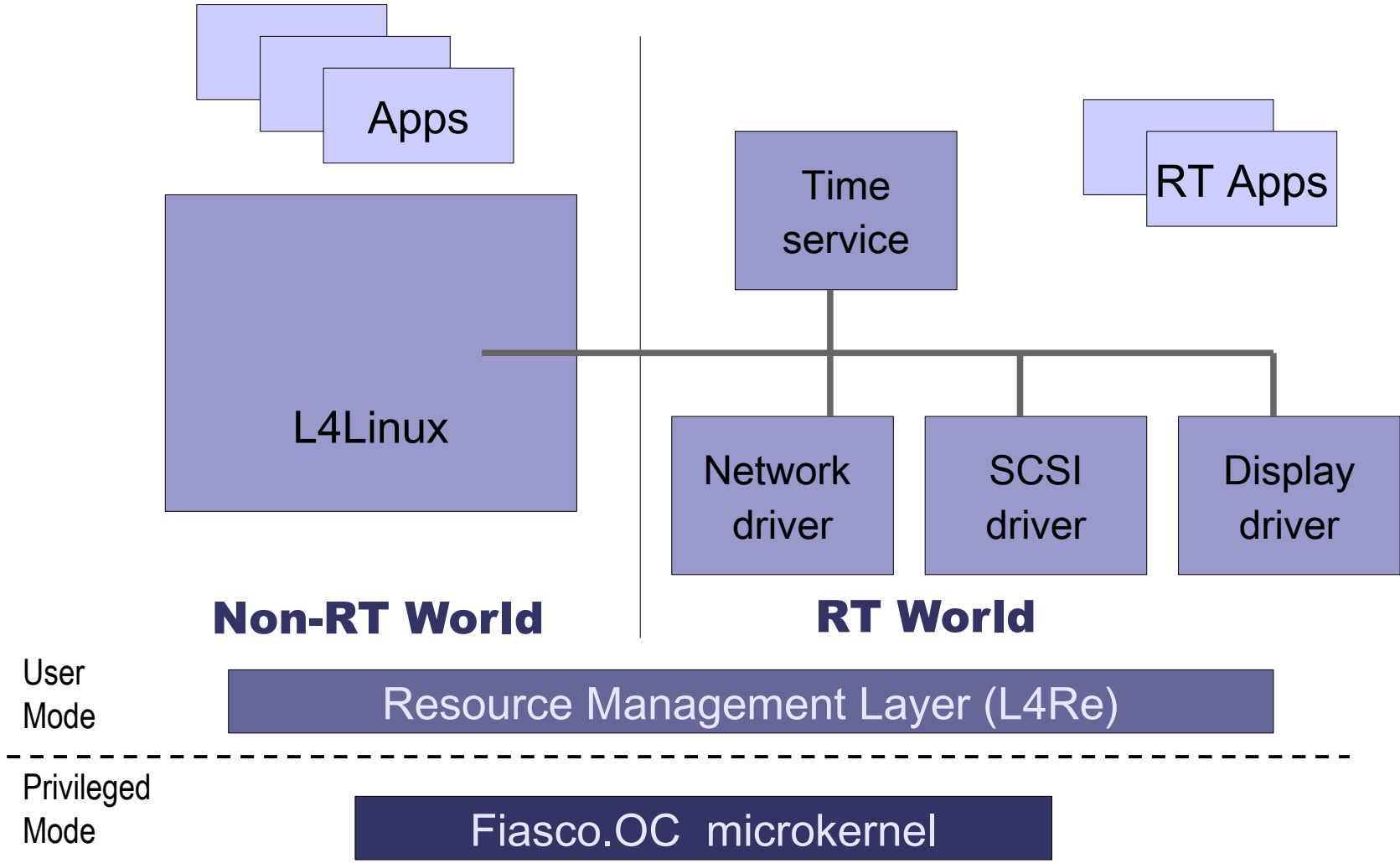

- Isolate not only processes, but also complete Operating Systems (compartments)
- “Server consolidation”

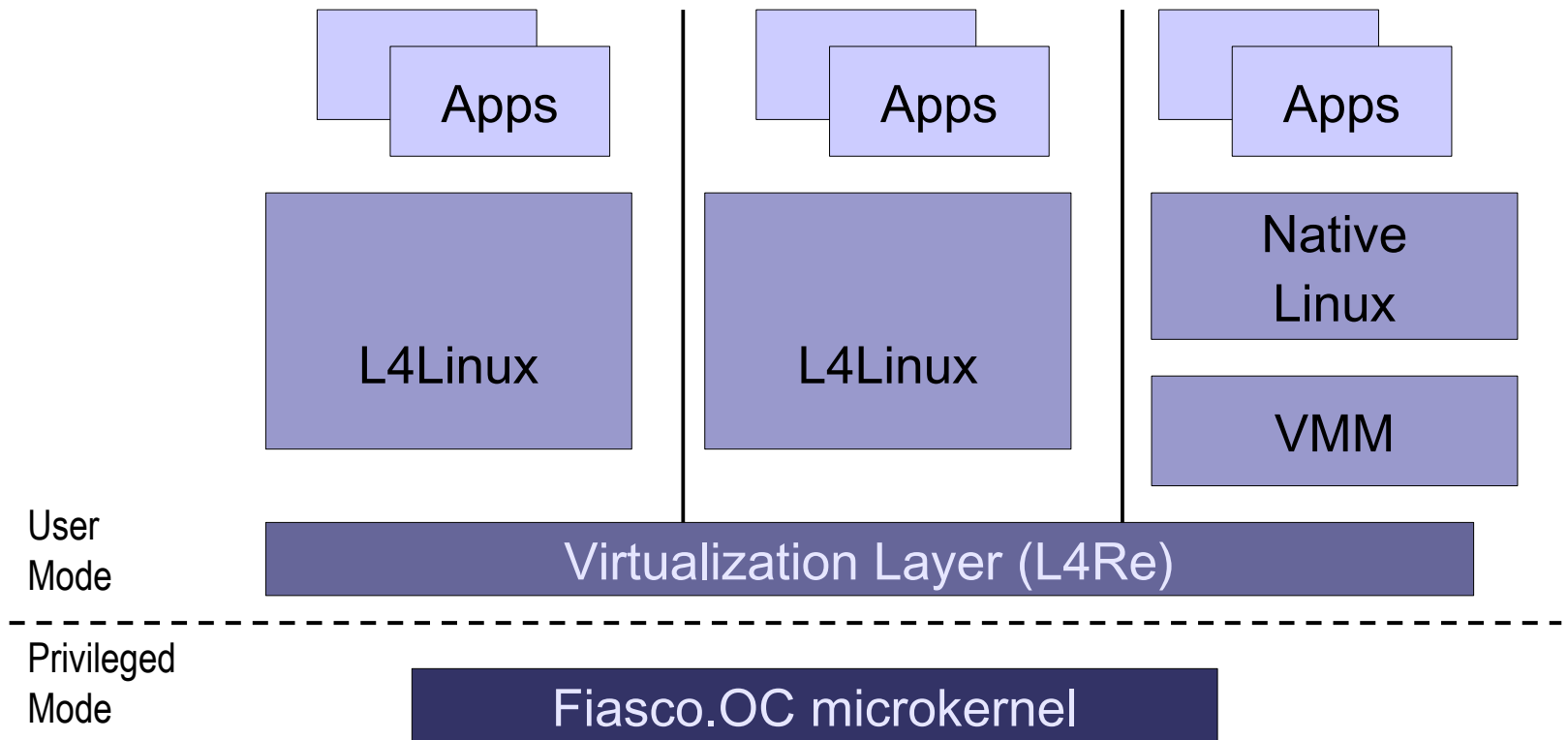

- Genode := C++-based OS framework developed here in Dresden
- Aim: hierarchical system in order to
 - Support resource partitioning
 - Layer security policies on top of each other

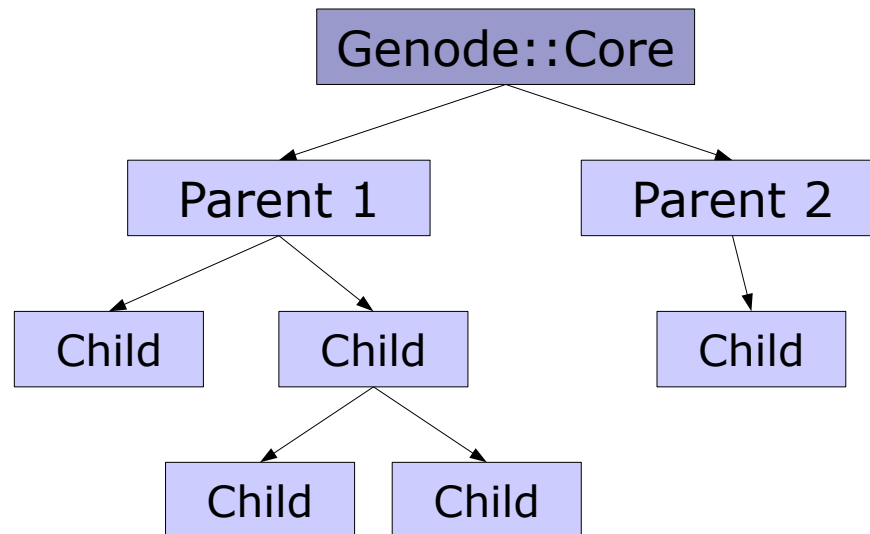

- **Basic mechanisms and concepts**
 - Memory management
 - Tasks, Threads, Synchronization
 - Communication
- **Building real systems**
 - What are resources and how to manage them?
 - How to build a secure system?
 - How to build a real-time system?
 - How to reuse existing code (Linux, standard system libraries, device drivers)?
 - How to improve robustness and safety?

- Next lecture:
 - “Inter-Process Communication”
 - Next week (Oct 16, 4:40 PM)
- First exercise:
 - Per Brinch-Hansen: *The nucleus of a multiprogramming system*
 - Next week (Oct 16, 2:50 PM)
 - **Read the paper! Link is on website!**