



**TECHNISCHE
UNIVERSITÄT
DRESDEN**

Department of Computer Science Institute of System Architecture, Operating Systems Group

SECURITY ARCHITECTURES

CARSTEN WEINHOLD

- Common observations:
 - Complex software has security bugs
 - Users are plagued by malware
 - User PCs become bots
 - Critical data gets stolen
 - Targeted attacks at high-value users:
 - Industry, governments, NGOs, ...
- Sad truth: threats won't go away

- It's all the same for mobile devices
- Malware in Android Store: trojan horse downloaded by millions of users
- Security-critical bugs:
 - Drivers [1,2], USB stacks [7], boot loaders
 - Messaging apps [8], web browser, ...
- „Jailbreaking“ = attack on security:
 - Requires physical access ...
 - ... or visit special website [9]

CLASSICAL ARCHITECTURES

- Isolation in commodity OSes based on user accounts:
 - Same privileges for all apps
 - Permissive interfaces (e.g., ptrace to manipulate other address spaces)
 - No isolation within applications
- Efforts to restrict privileges:
 - SELinux, AppArmor, Seatbelt, ...

- Separate computers
- Applications and data physically isolated
- Effective, but ...
 - High costs
 - Needs more space
 - Inconvenient
 - Exposure to network may pose threat

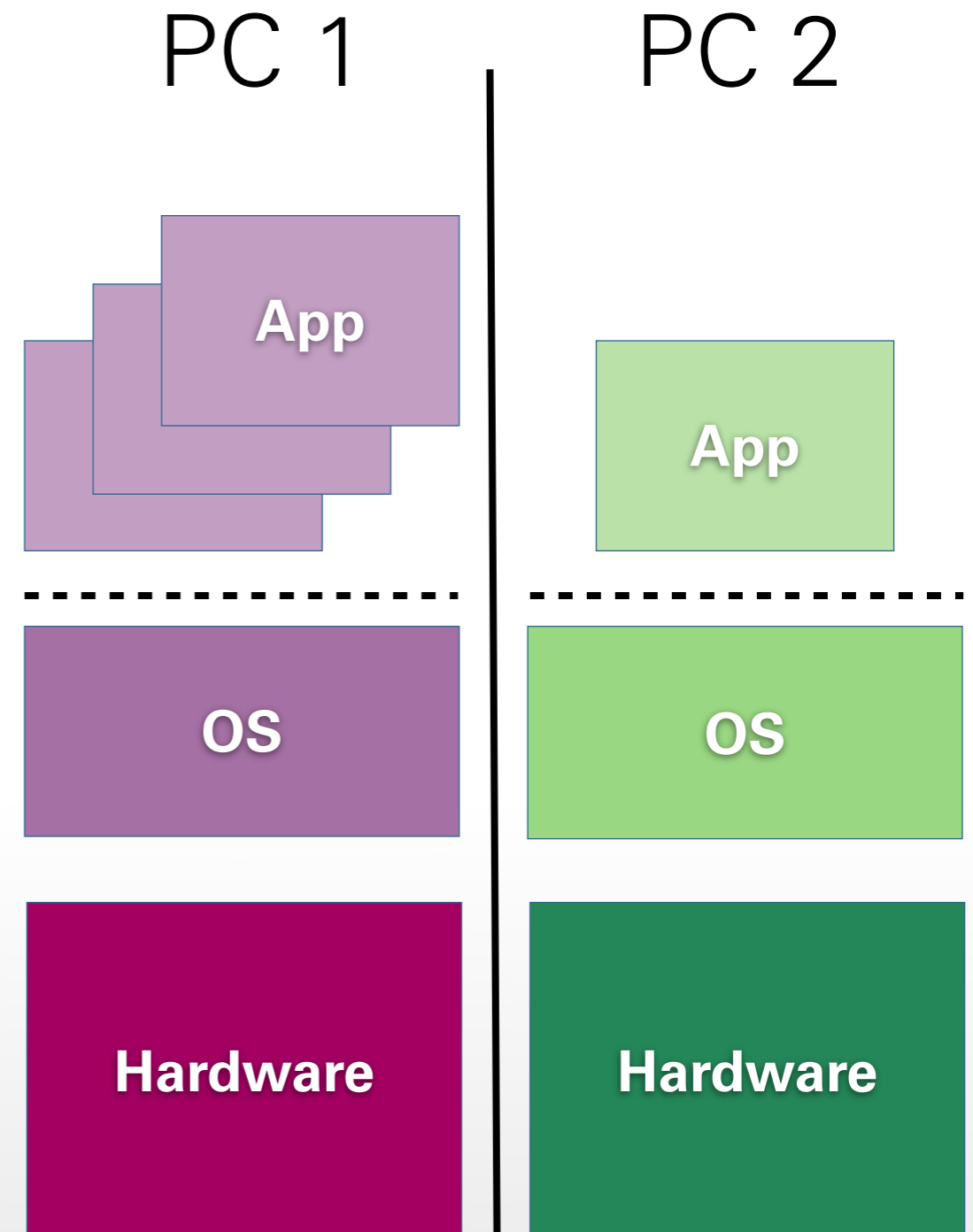

- Multiple VMs, OSes
- Isolation enforced by virtualization layer
- Saves space, energy, maintenance effort
- But still ...
 - Switching between VMs is inconvenient
 - Even more code

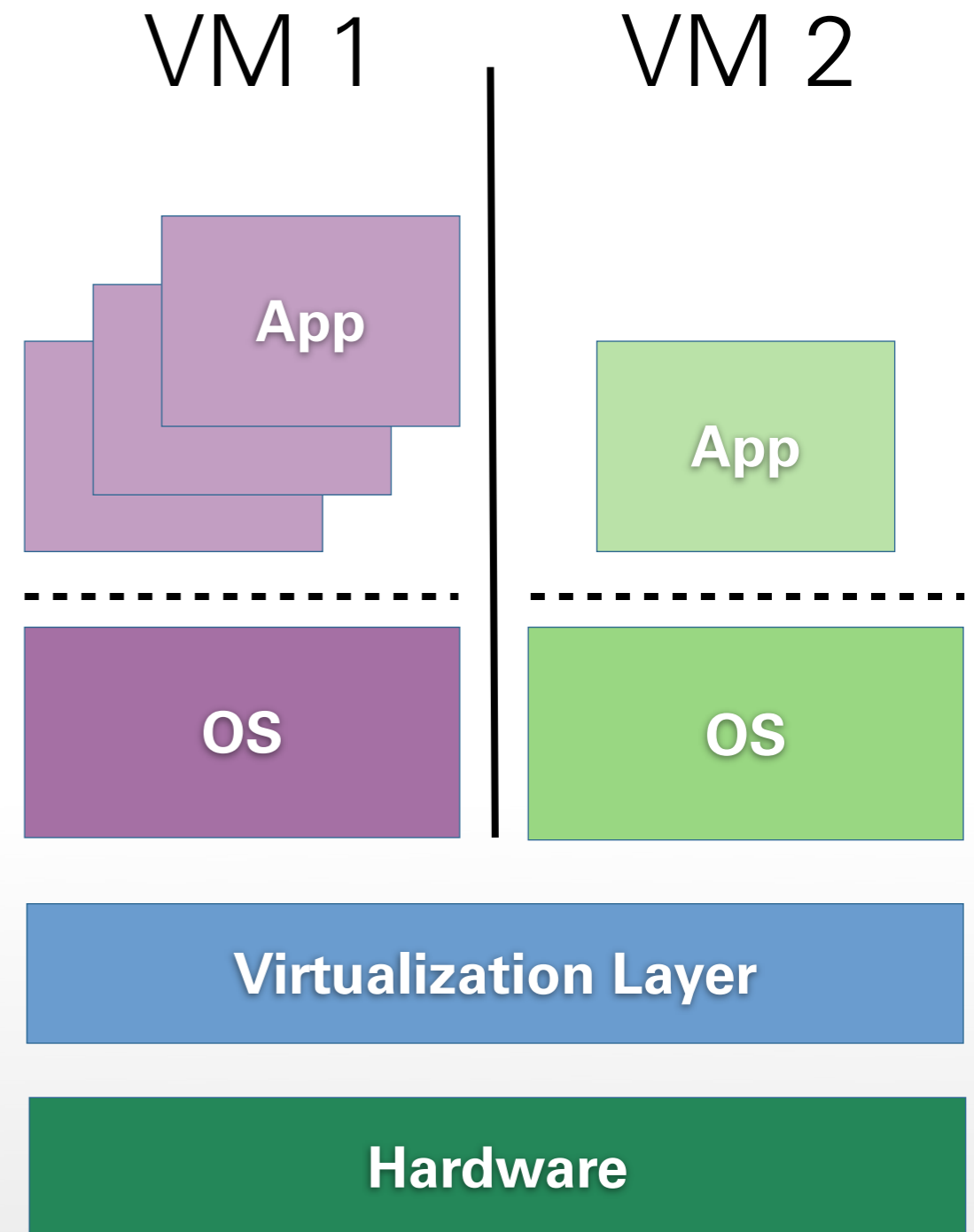

- Huge code bases remain
- Applications still the same
- Many targets to attack:
 - Applications, libraries, commodity OSes
 - Virus scanner, firewall, ...
 - Virtualization layer
- High overhead for many VMs

SECURITY ARCHITECTURES

- Protect the user's data
- Secure applications that process data
- Acknowledge different kinds of trust:
 - Application **A** trusted for task *B*, but not *C*
 - OS trusted to store data, but not to see it
- Use infrastructure without trusting it?
- Identify and secure **TCB**: the **T**rusted **C**omputing **B**ase

- To improve security: Reduce size of TCB = smaller attack surface
- First idea:
 - Remove huge legacy OS from TCB
 - Port application to microkernel-based multi-server OS
 - Remove unneeded libc backends, etc.
 - Possible approaches discussed in lecture on „Legacy Reuse“

NIZZA ARCHITECTURE

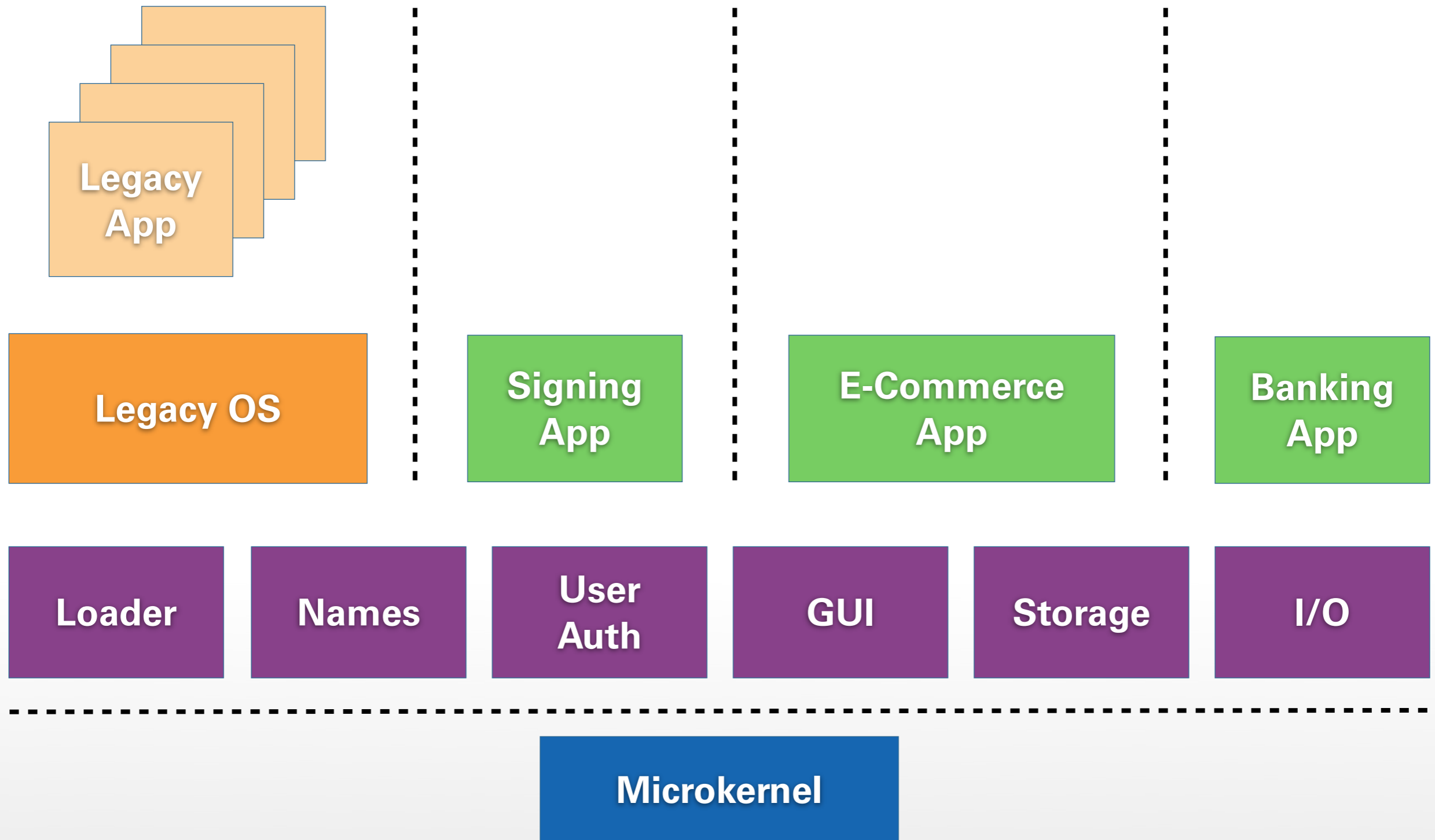

Nizza architecture: fundamental concepts:

- Strong isolation
- Application-specific TCBs
- Legacy reuse
- Trusted wrappers
- Trusted computing

- Reflects **Principle of Least Privilege**
- TCB of an application includes only components its security relies upon
- TCB does not include unrelated applications, services, libraries
- Mechanisms:
 - Address spaces, IPC control for isolation
 - Well-defined interfaces

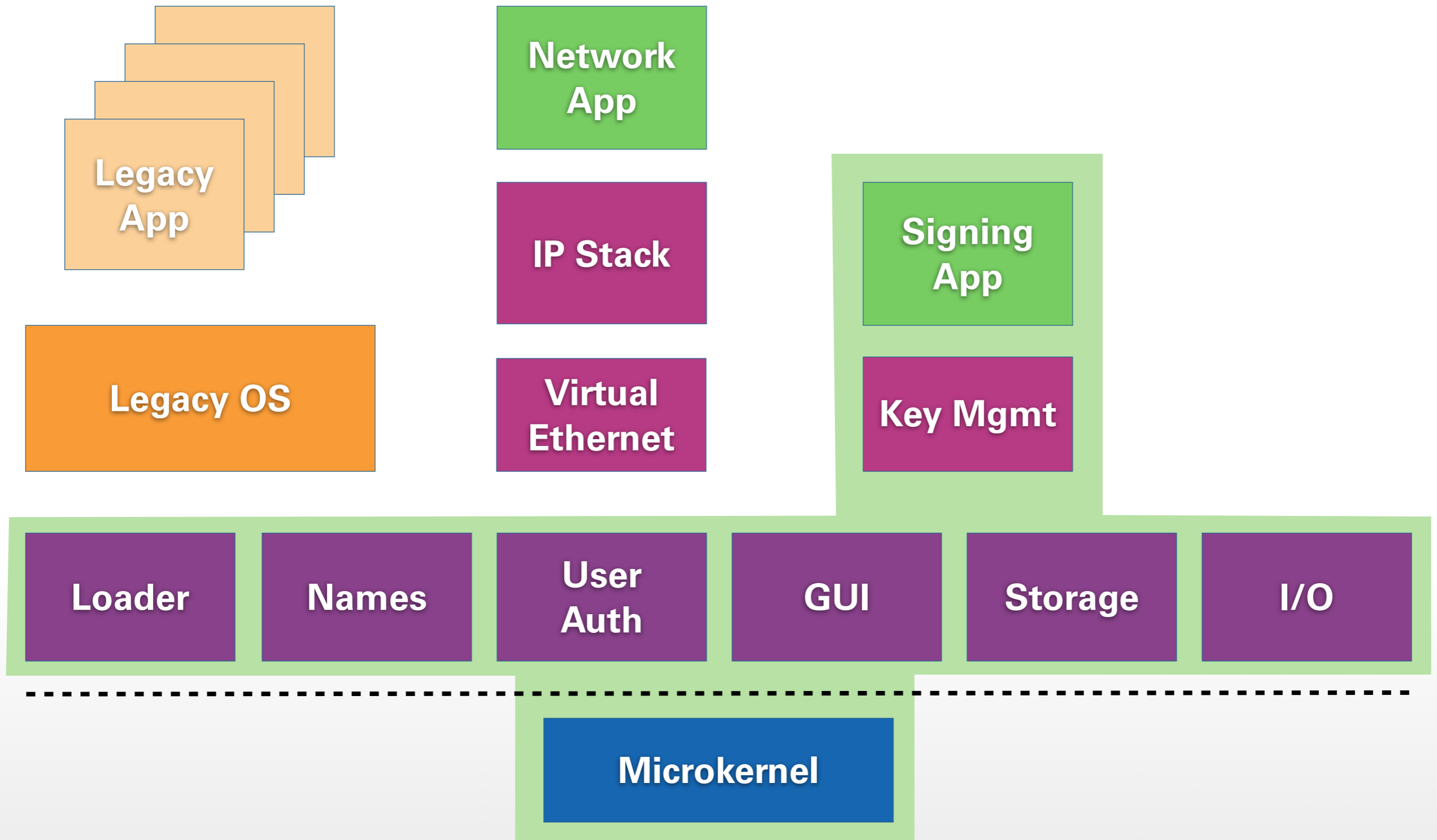

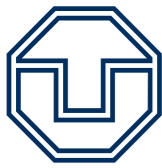

SPLITTING COMPONENTS

- Problems with porting applications:
 - Dependencies need to be satisfied
 - Can be complex, require lots of code
 - Stripped down applications may lack functionality / usability
- Better idea: split application
 - Make only security-critical parts run on microkernel-based OS
 - Parts of application removed from TCB

Digitally signed e-mails, what's critical?

- Handling of signature keys
- Requesting passphrase to unlock secret signature key
- Presenting e-mail message:
 - Before sending: „**W**hat **Y**ou **S**ee **I**s **W**hat **Y**ou **S**ign“
 - After receiving: verify signature, identify sender

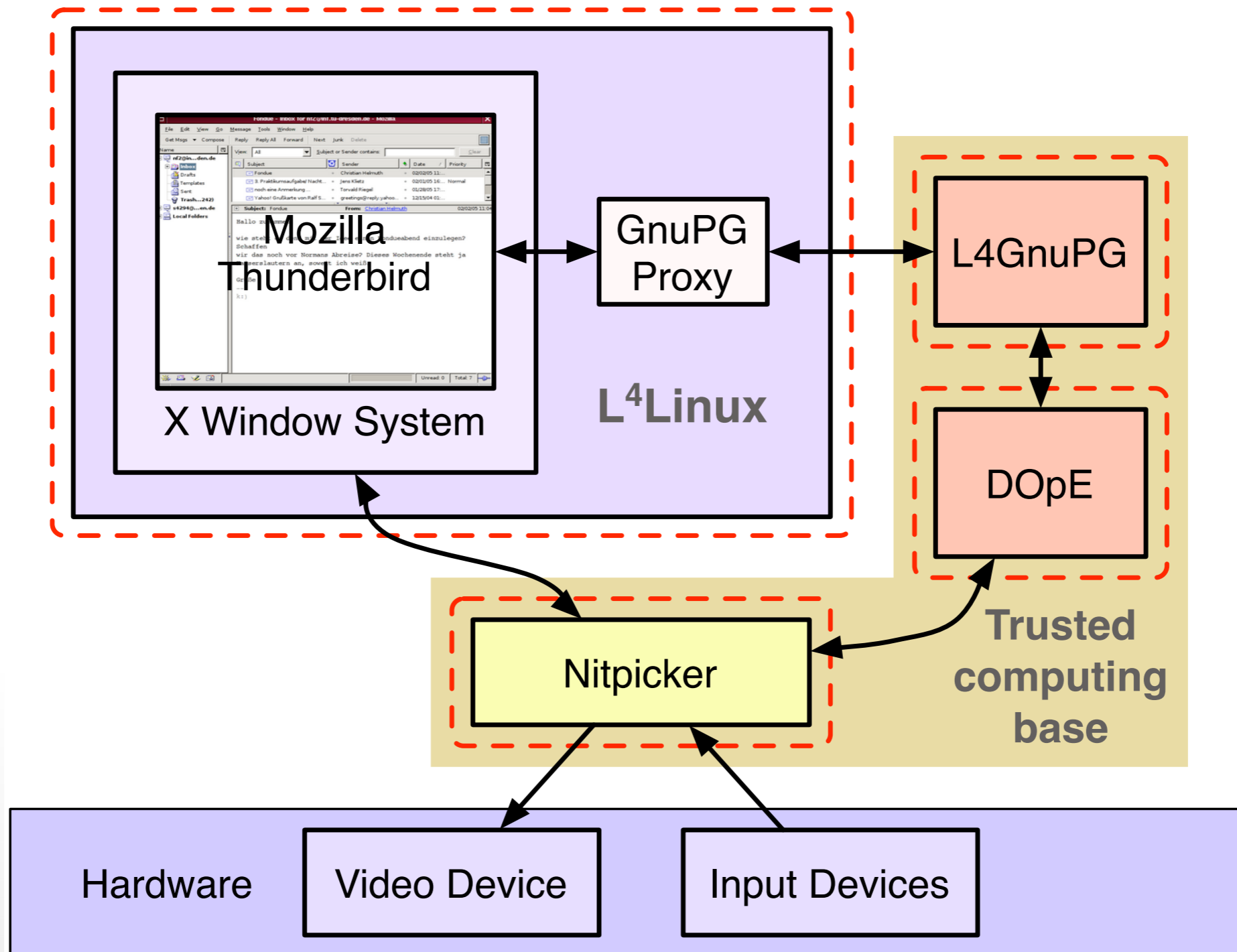
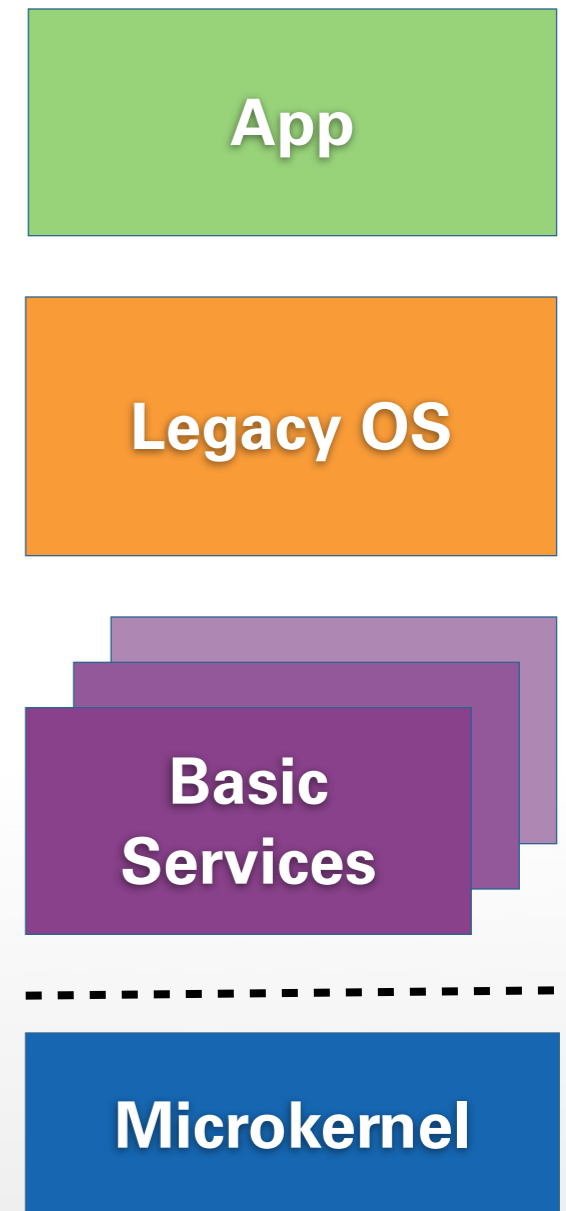

Figure taken from [5]

- *1,500,000+* SLOC no longer in TCB:
 - Linux kernel, drivers, X-Server
 - C and GUI libraries, Thunderbird
- TCB size reduced to *~150,000* SLOC:
 - GNU Privacy Guard, e-mail viewer
 - Basic L4 system
- At least 10 times less code in TCB

- Splitting works for applications
- What about the complex and useful infrastructure of commodity OSes?
 - Drivers (see previous lectures)
 - Protocol stacks (e.g., TCP/IP)
 - File systems
- Starting point: Virtualized commodity OS

- Run legacy OS in VM
- Reuse service: net, files, ...
- Legacy infrastructure isolated from applications
- But:
 - Applications still depend on legacy services ... in TCB?
 - Interfaces reused, security issues as well?



- Network and file system stacks are virtually essential subsystems
- Generally well tested
- Ready for production use
- ... but not bug free: month of Kernel Bugs 2006 [1,2]:
 - 14 exploitable flaws in file systems: UFS, ISO 9660, Ext3, SquashFS, ...
 - WiFi drivers: remotely exploitable bugs

- Complex protocol stacks should not be part of TCB (for confidentiality + integrity)
- Reuse untrusted infrastructure through trusted wrapper:
 - Add security around existing APIs
 - Cryptography
 - Redundancy
- General idea similar to SSL, VPN

VPN: Confidentiality, Integrity, ~~Availability~~

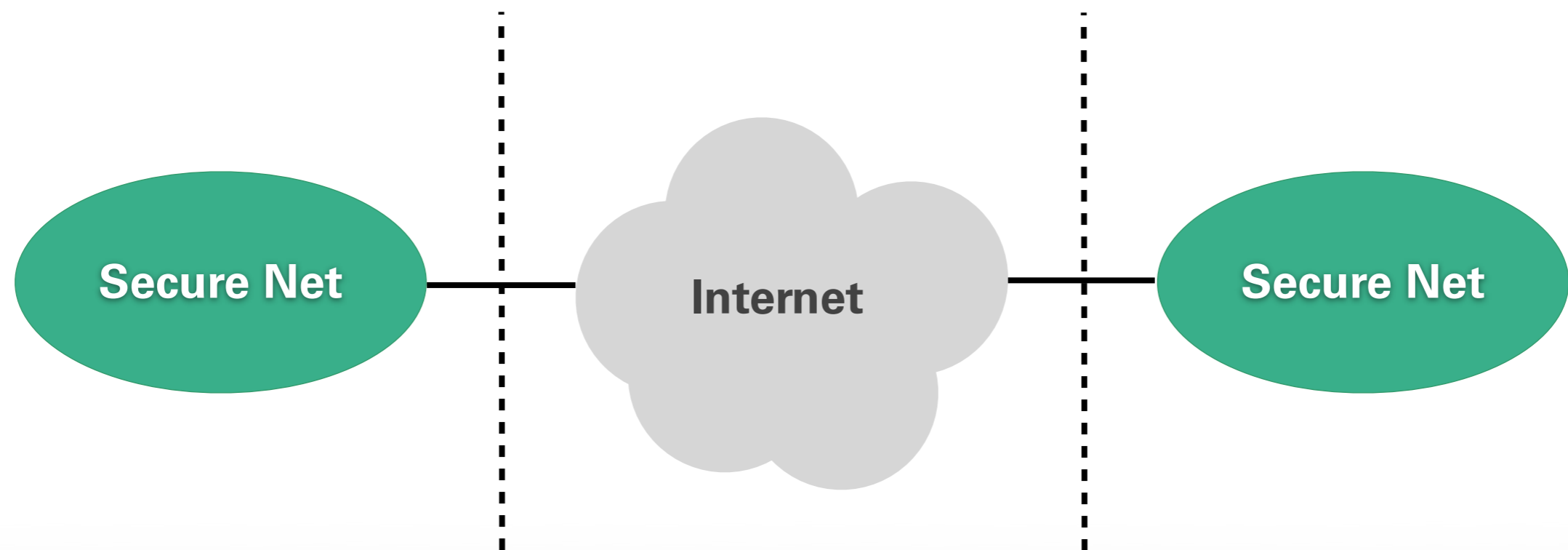

- SINA box used by German „BSI“:
 - VPN gateway
 - Implements IPSec & PKI
 - Intrusion detection & response
- Used for secure access to government networks, e.g. in German embassies



Image source:
<http://www.secunet.com/de/das-unternehmen/presse/bilddatenbank/>

- Hardware:
 - Differently trusted network interfaces:
 - Red: plaintext, no protection
 - Black: encrypted, MACs
 - Tamper / EM protected casing
- Software:
 - Minimized and hardened Linux
 - Runs only from CD-ROM or Flash

- Linux is complex!
- SLOC for Linux 2.6.18:
 - Architecture specific: 817,880
 - x86 specific: 55,463
 - Drivers: 2,365,256
 - Common: 1,800,587
- Typical config: ~ 2,000,000
- Minimized & hardened: ~ 500,000

- Research project „Mikro-SINA“
- Goals:
 - Reduce TCB of VPN gateway
 - Enable high-level evaluation for high assurance scenarios
 - Ensure confidentiality and integrity of sensitive data within the VPN
 - Exploit microkernel architecture

- Protocol suite for securing IP-based communication
- Authentication header (**AH**)
 - Integrity
 - Authentication
- Encapsulating Security Payload (**ESP**)
 - Confidentiality
- Tunnel mode / transport mode

Application

TCP / UDP

IP

IPSec

Link Layer

- IPsec is security critical component
- ... but is integrated into Linux kernel

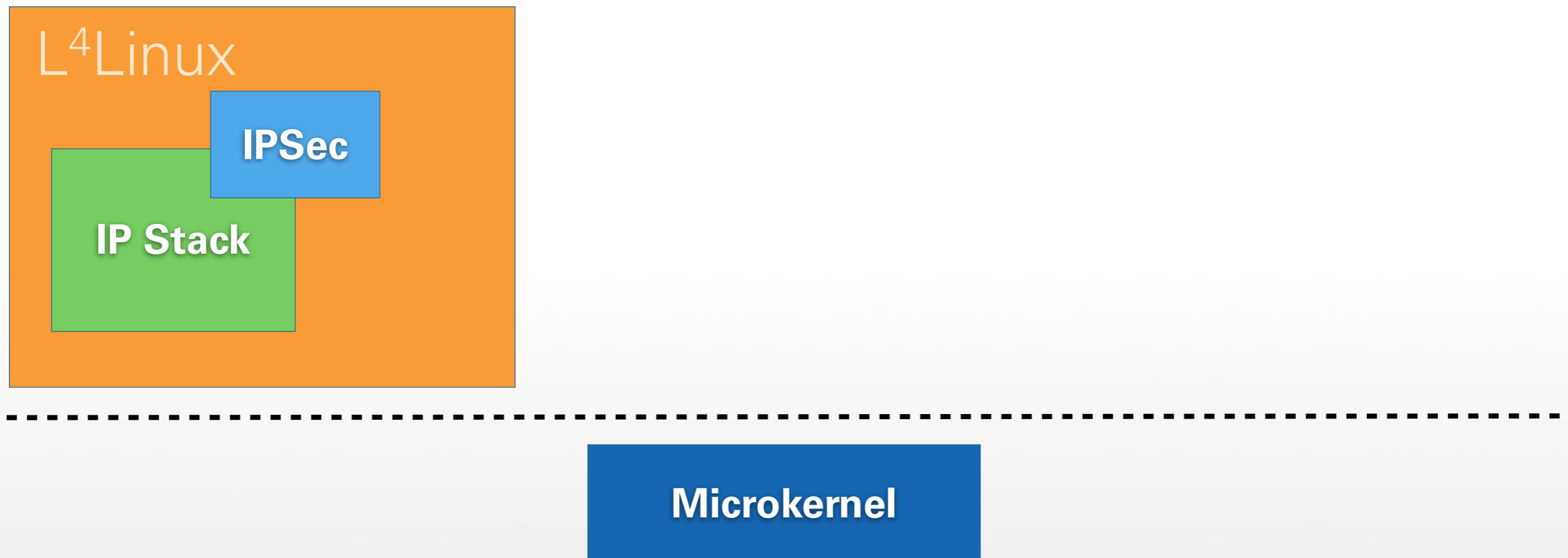

- Better: isolate IPsec in „Viaduct“
- IPsec packets sent/received through TUN/TAP device

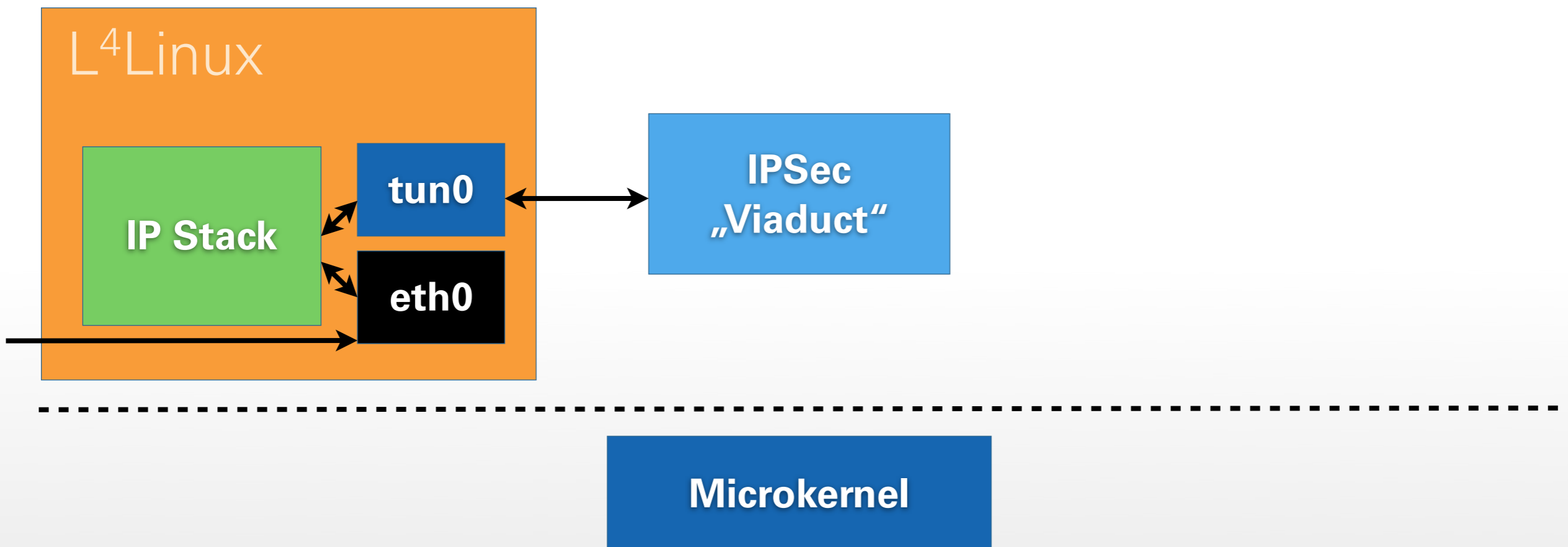

- Problem: Routers can fragment IPSec packets on the way
- Let L⁴Linux reassemble them

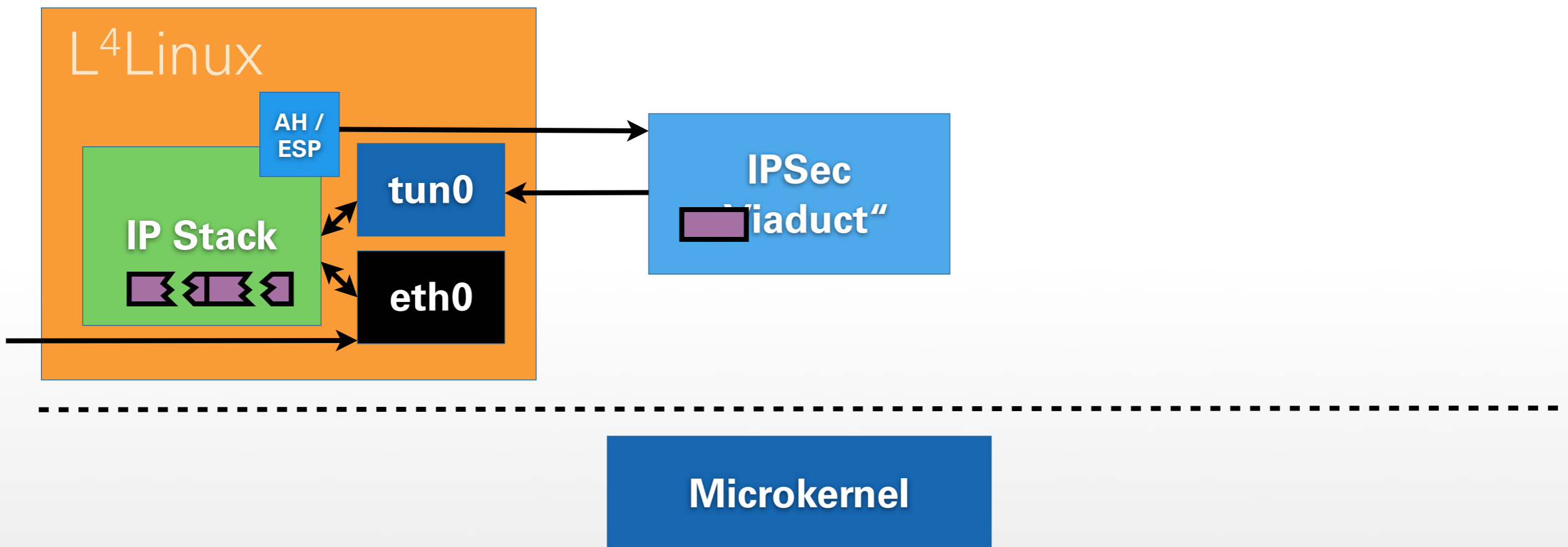

- Untrusted L⁴Linux must not see both plaintext and encrypted data
- Dedicated L⁴Linux for black/red networks

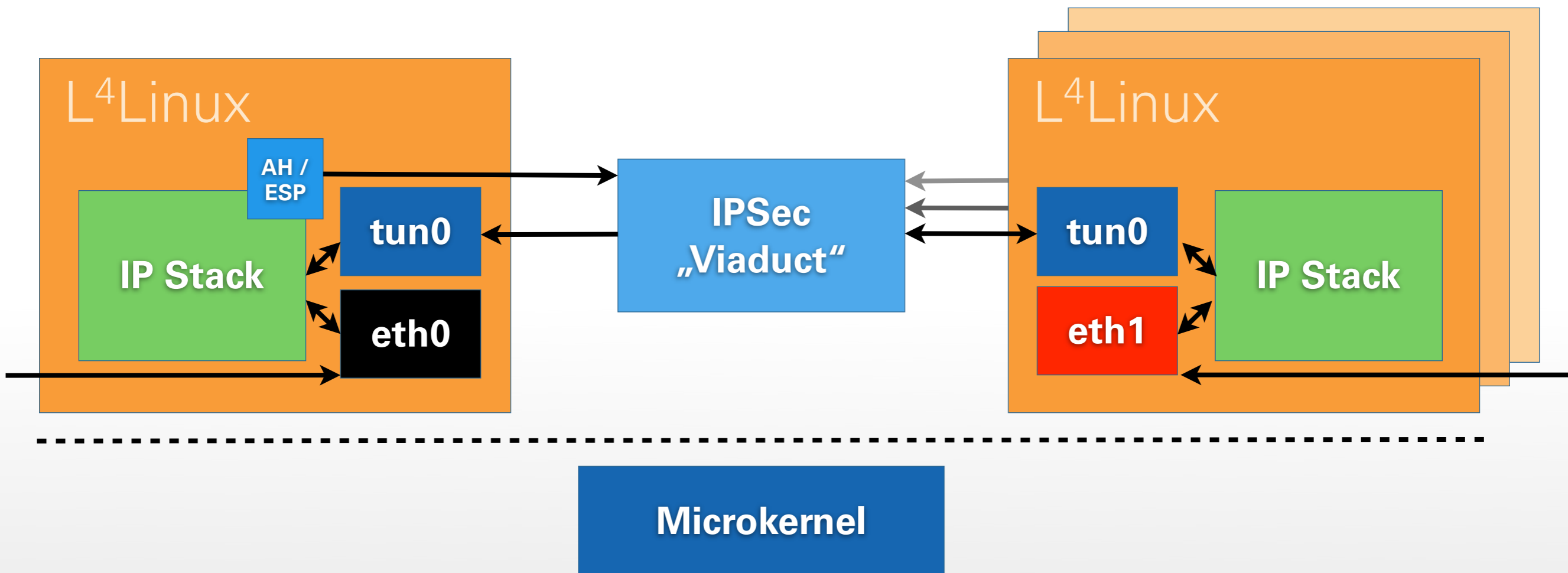

- Result: trusted wrapper for VPN
- Small TCB (see [6] for details):
 - 5,000 SLOC for „Viaduct“
 - Fine grain isolation
 - Principle of least privilege
- Extensive reuse of legacy code:
 - Drivers
 - IP stack

EXAMPLE: STORAGE

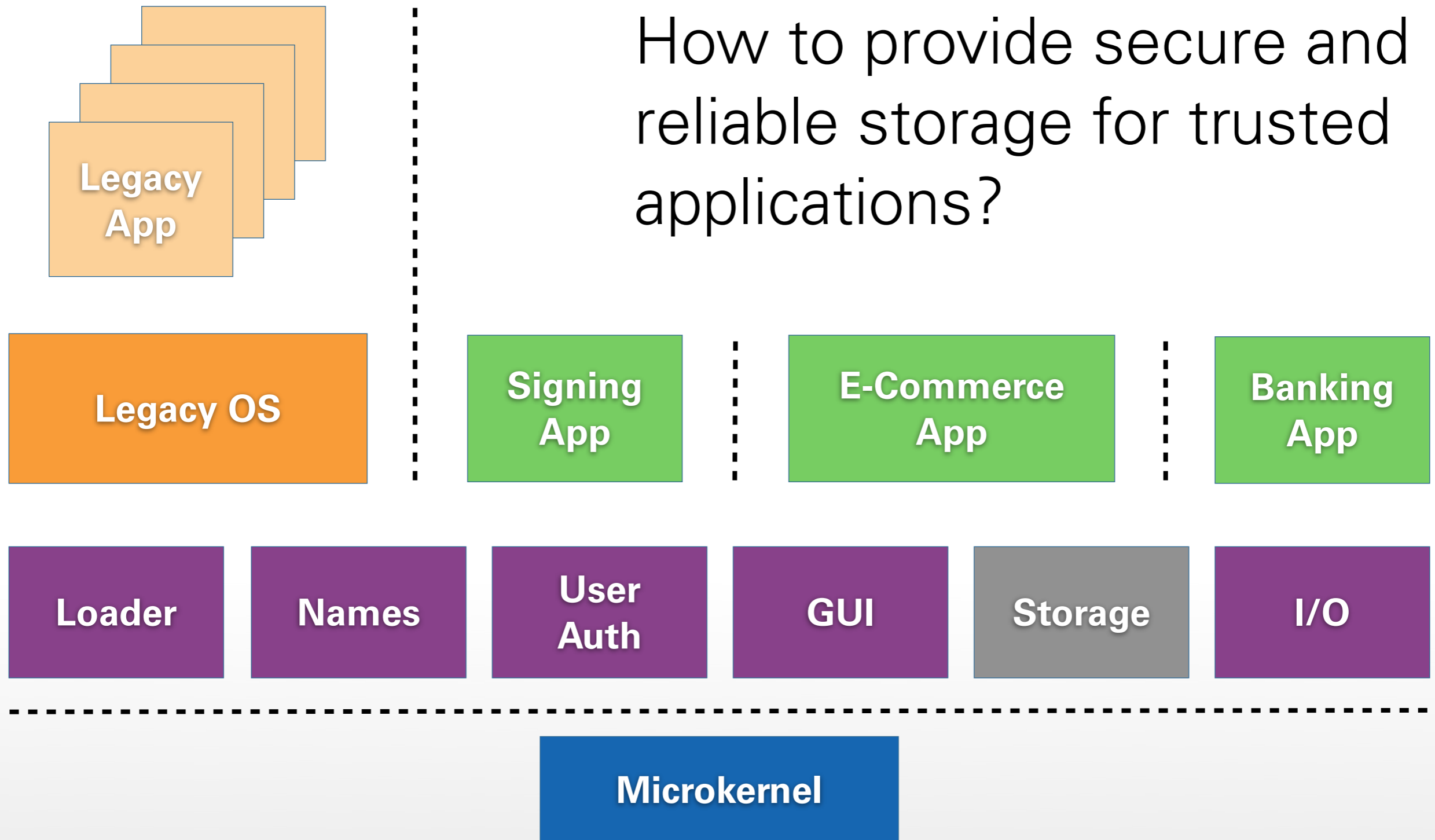

- Private Storage for isolated applications
- Restrict communication capabilities

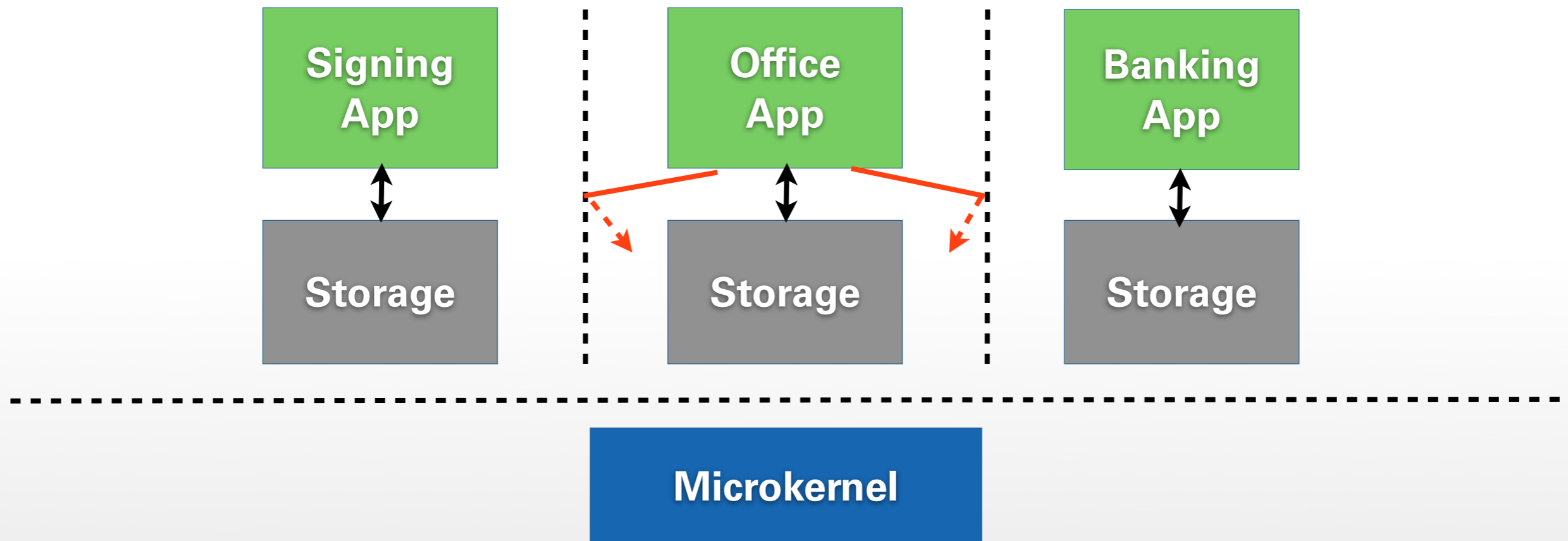

VPFS: Confidentiality, Integrity, ~~Availability~~

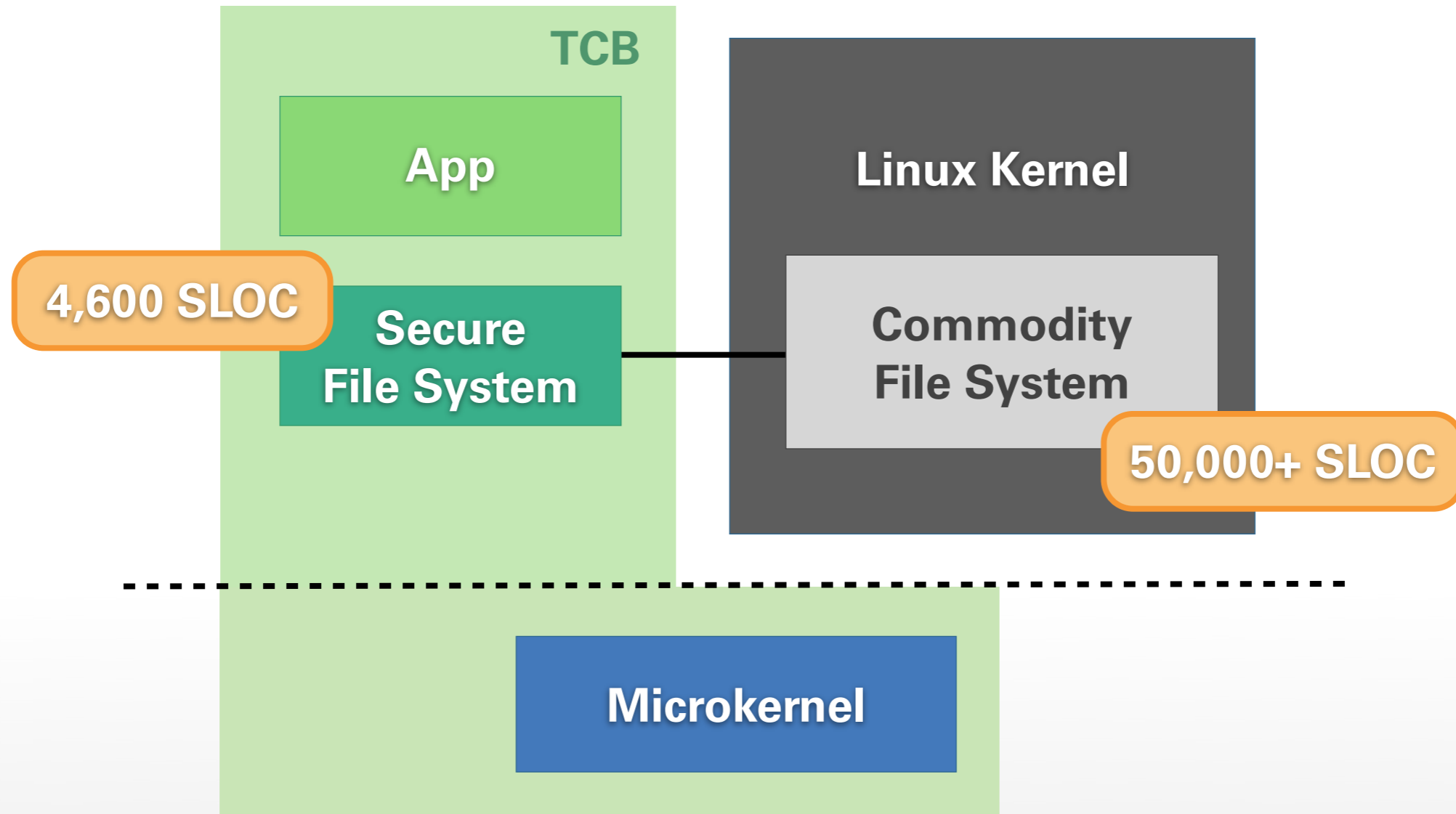

See [3] for details

App

Secure File
System Helper

Commodity
File System

- **Confidentiality:** only authorized applications can access file system, all untrusted software cannot get any useful information
- **Integrity:** all data and meta data is correct, complete, and up to date; otherwise report integrity error
- **Recoverability:** damaged data in untrusted file system can be recovered from trusted backup

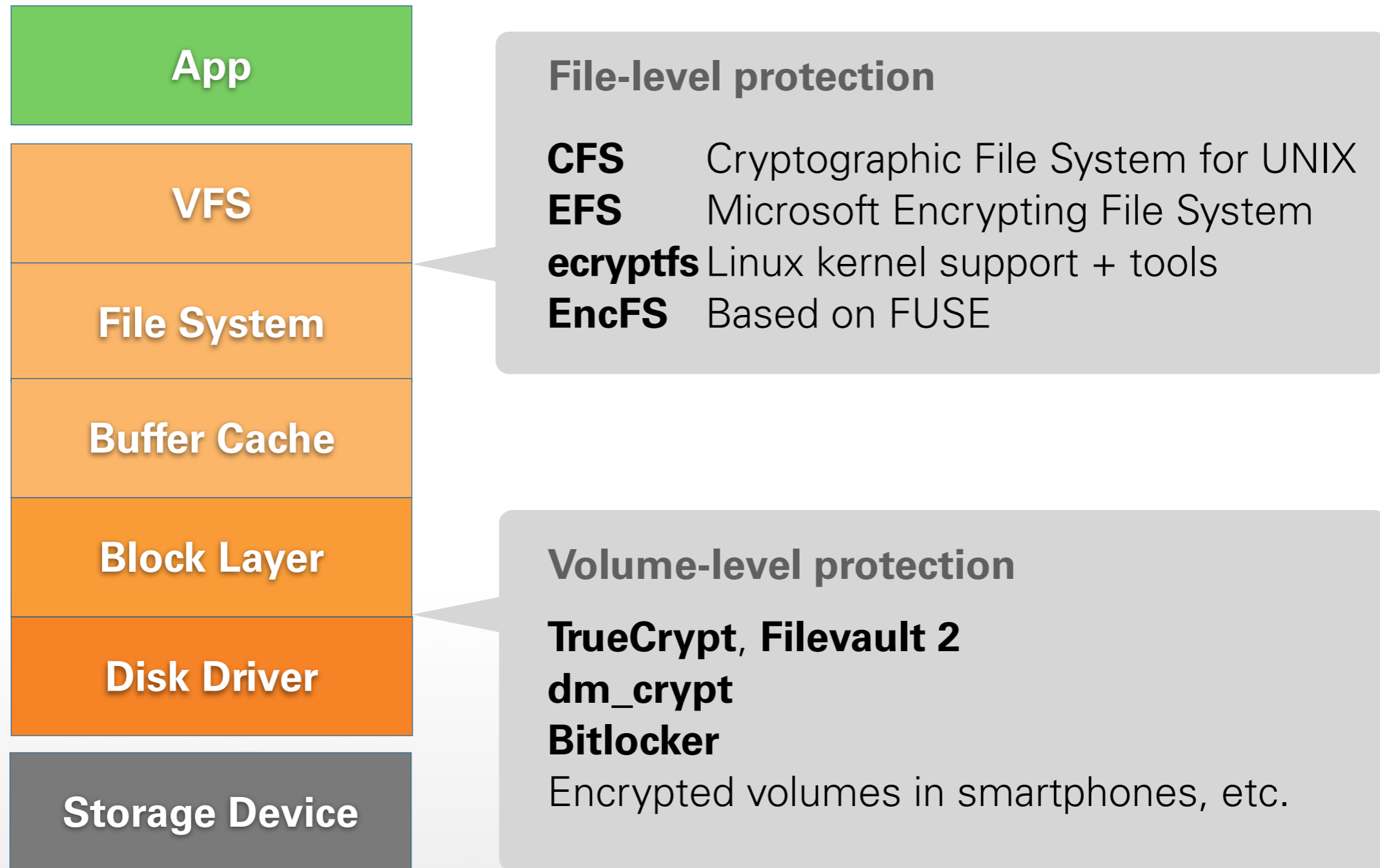

- First end of design space:
Protect whole file system at
block layer:
- Transparent encryption of all
data and metadata
- Block-level integrity ???
- Most parts of file system stack
are part of TCB
- Attack surface still big

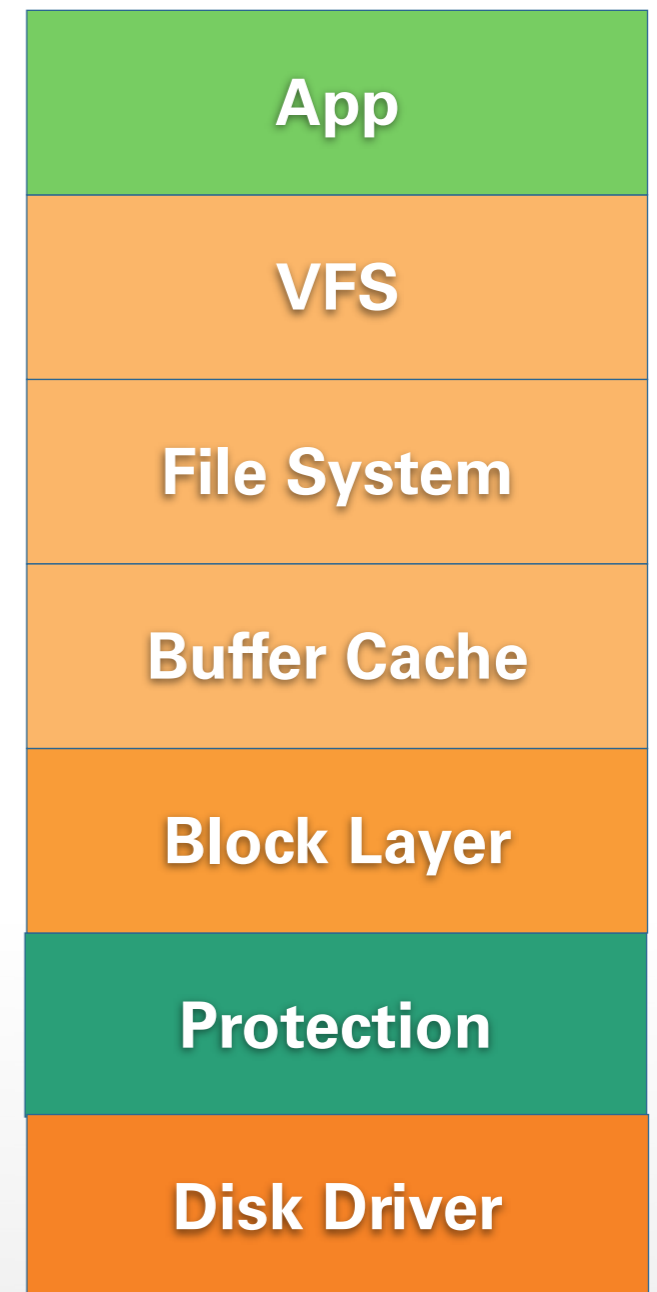

- Second end of design space:
Protect individual files:
 - Stacked file system
 - Encryption of all data and some metadata (names, directories, ...)
 - More flexibility for integrity
 - Most parts of file system stack not part of TCB
 - Ideal for trusted wrapper

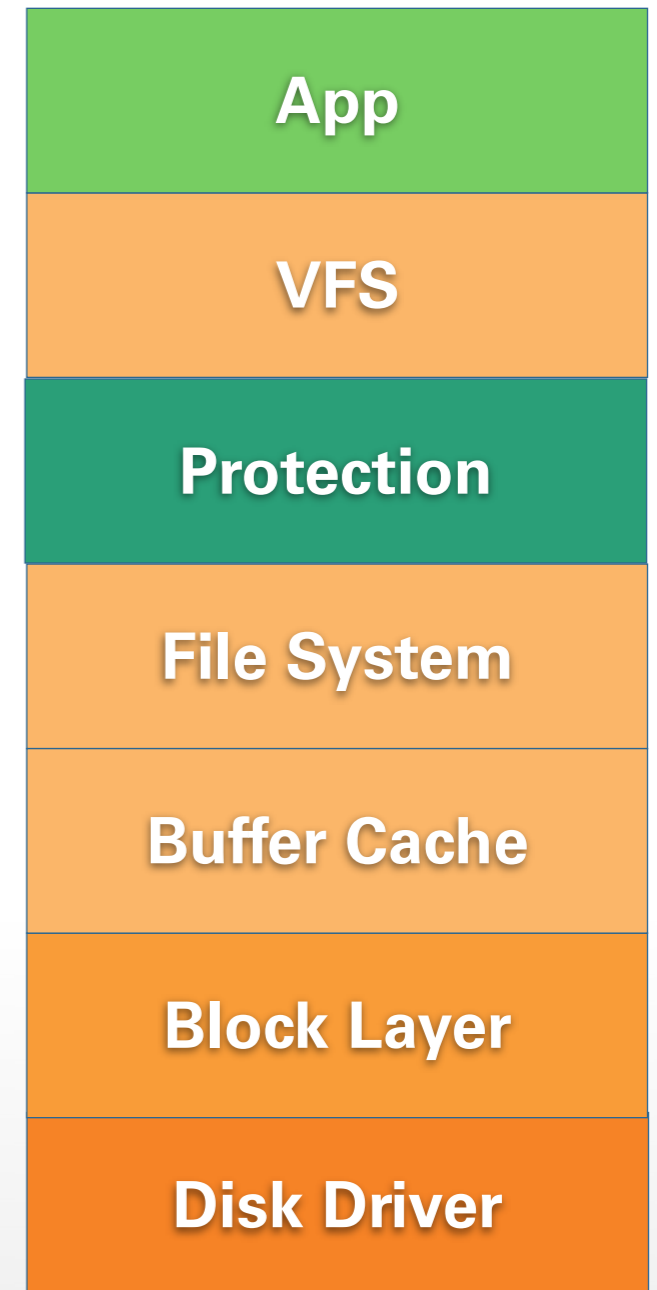

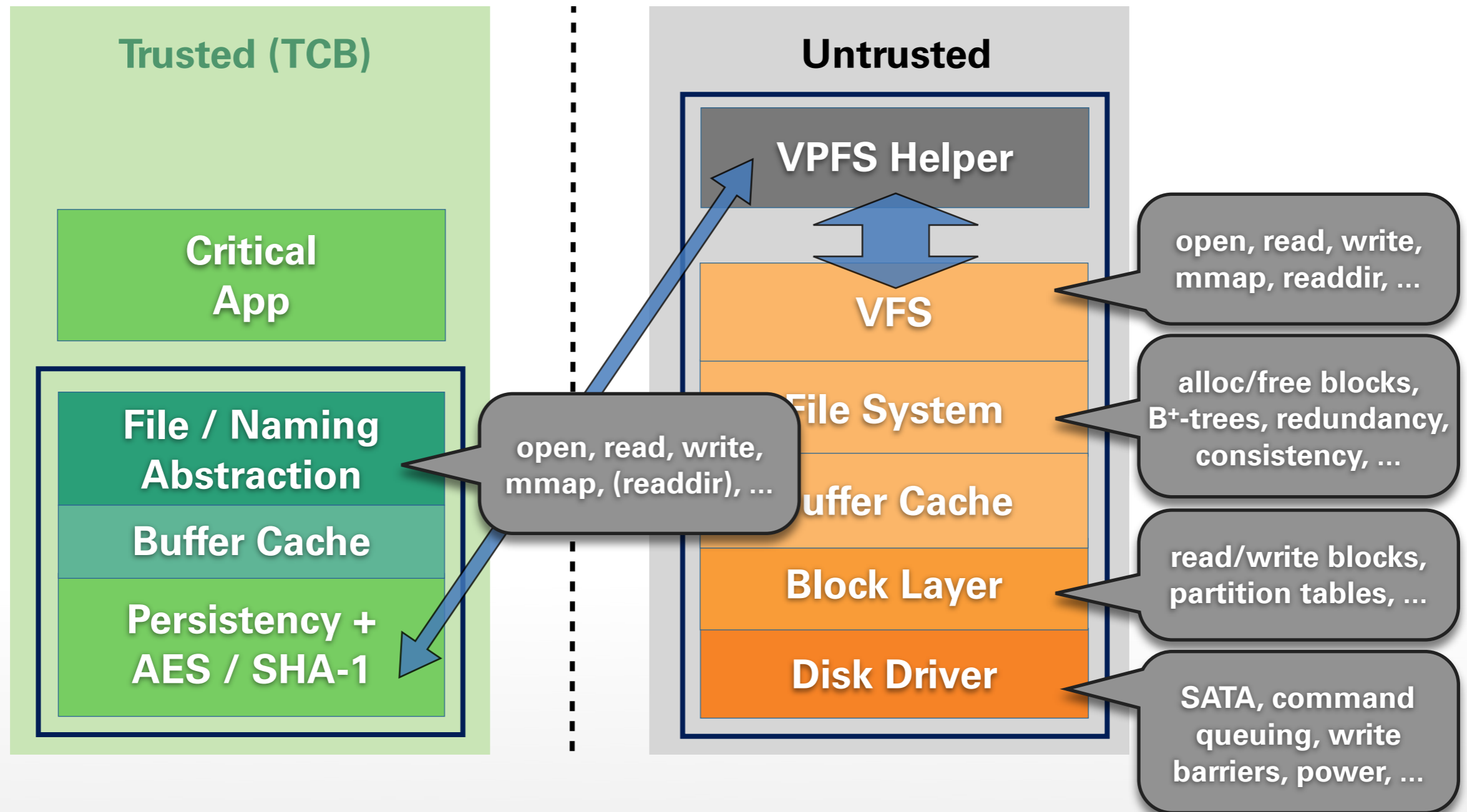

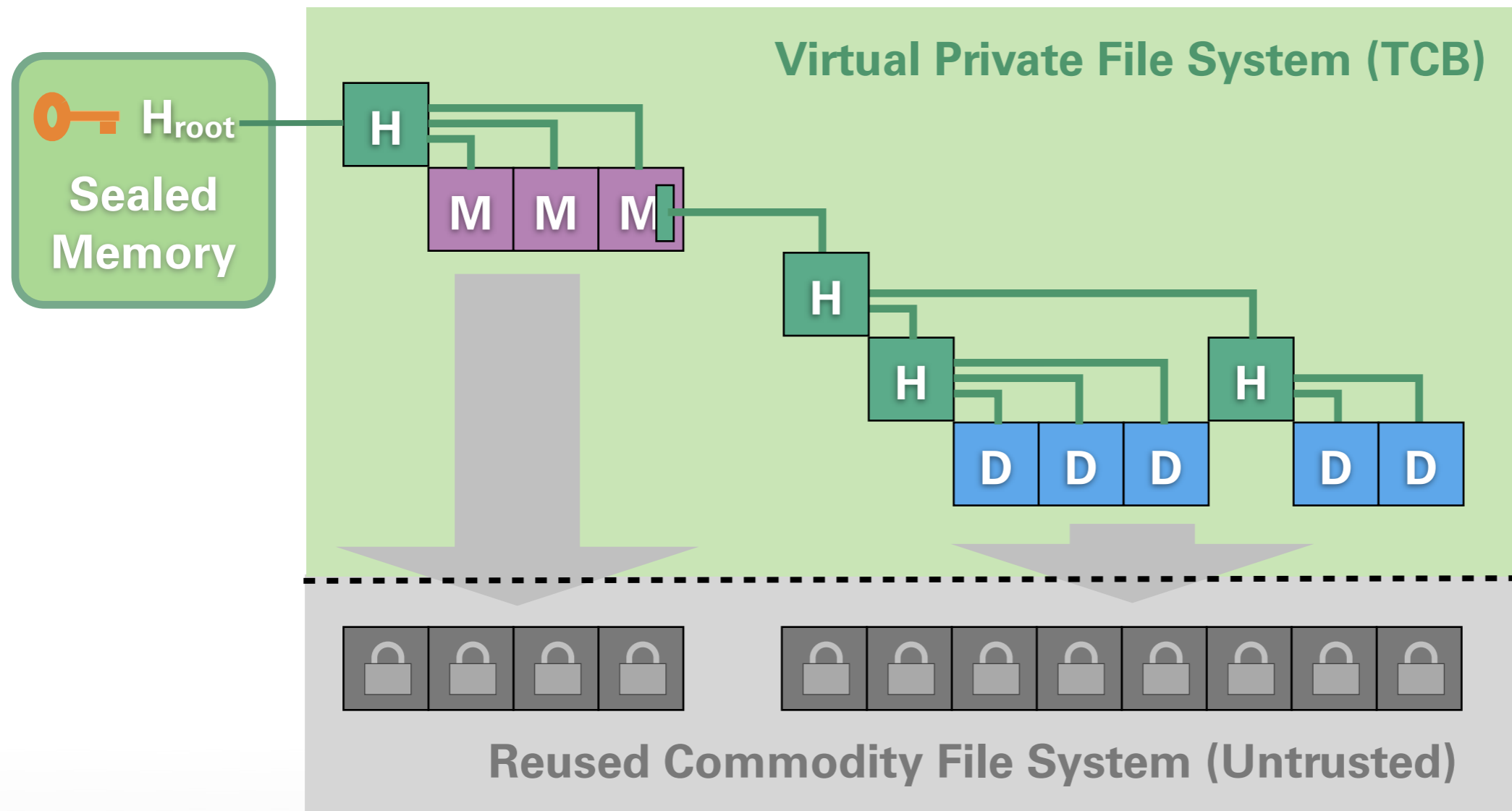

- Encrypted files in commodity file system
- Merkle **hash tree** to detect tampering

- Trusted part of VPFS enforces security:
 - Encryption / decryption on the fly
 - Plaintext only in trusted buffer cache
 - Files in untrusted commodity file system store encrypted blocks
 - Hash tree protects integrity of complete file system
 - Single hash of root node stored securely

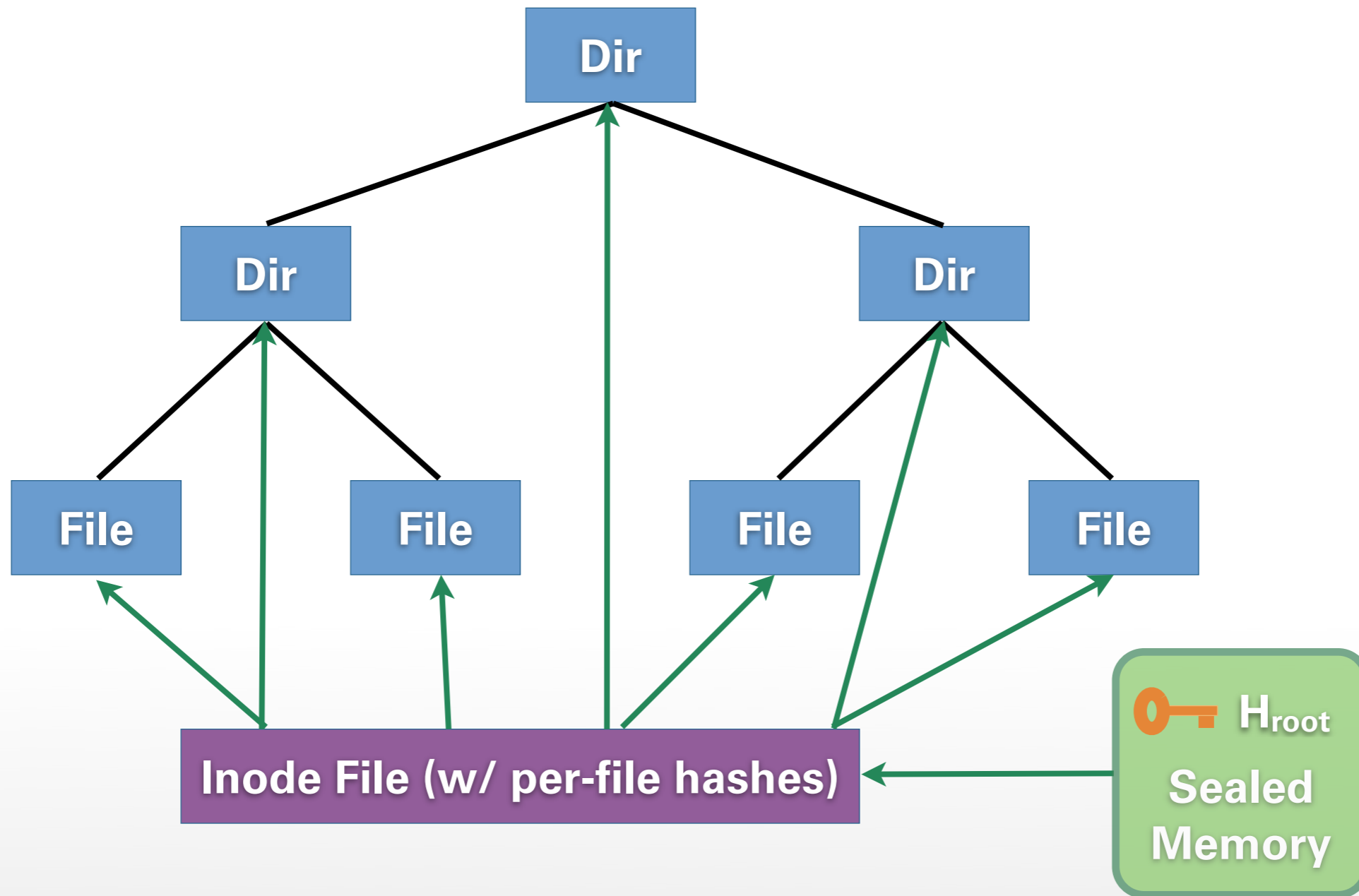

- VPFS reuses Linux file system stack:
 - Drivers, block device layer
 - Optimizations (buffer cache, read ahead, write batching, ...)
 - Allocate / free disk storage for files
- Cooperation: proxy driver in L⁴Linux

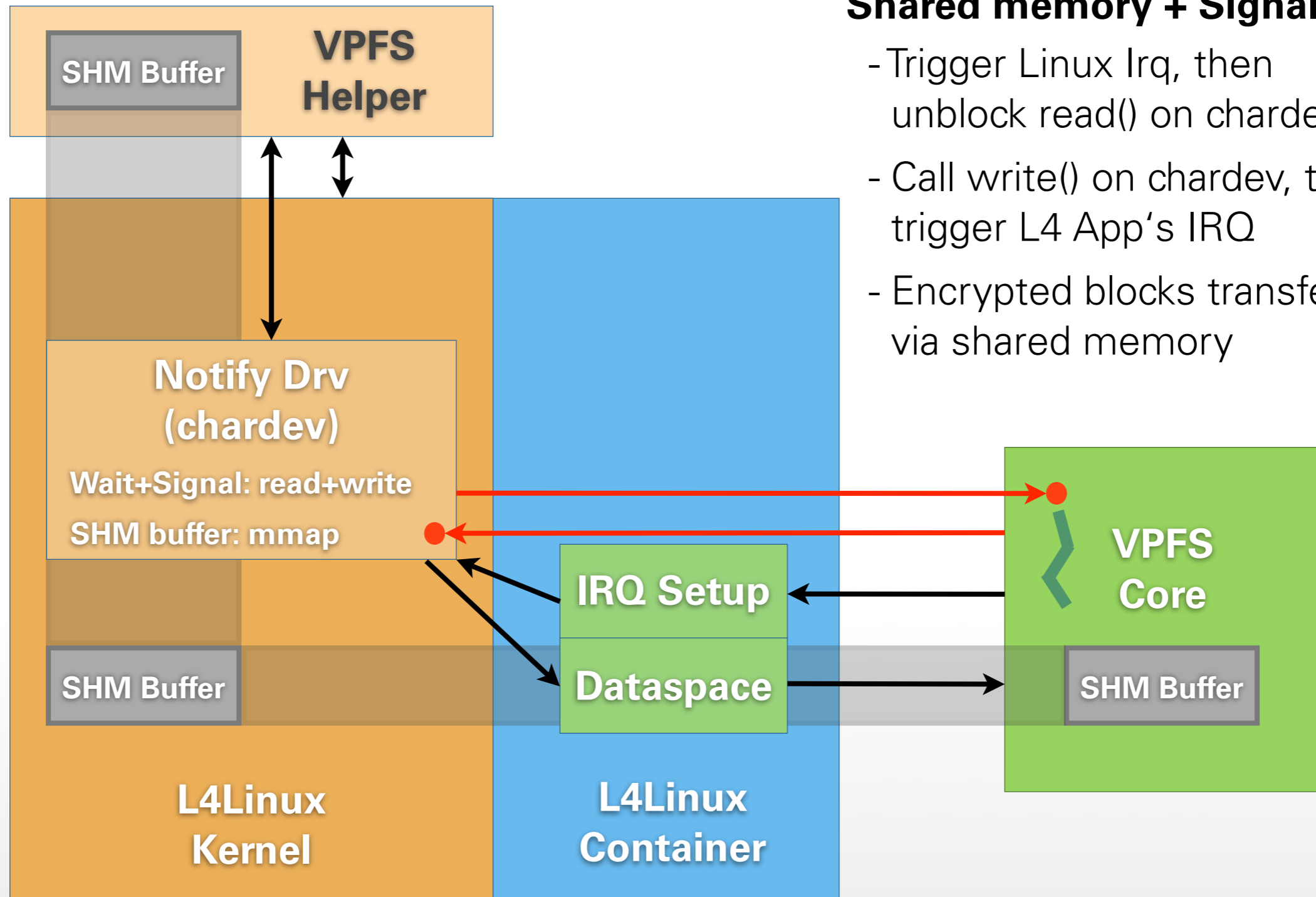

Shared memory + Signaling:

- Trigger Linux Irq, then unblock read() on chardev
- Call write() on chardev, then trigger L4 App's IRQ
- Encrypted blocks transferred via shared memory

- Trusted wrappers for file systems work!
- VPFS is general purpose file system
- Significant reduction in code size:
 - Untrusted Linux file system stack comprises **50,000+** SLOC
 - VPFS adds **4,000** to **4,600** SLOC to application TCB [3]
 - jVPFS adds another **350** SLOC for secure journaling to protect against crashes [4]

USER INTERFACES

- Isolated applications run in different domains of trust, but separate screens are inconvenient
- The Nitpicker solution [5]:
 - Let all windows share the same screen ...
 - ... but securely:
 - Make windows & applications identifiable
 - Prevent them from spying on each other: route input securely, no screenshots

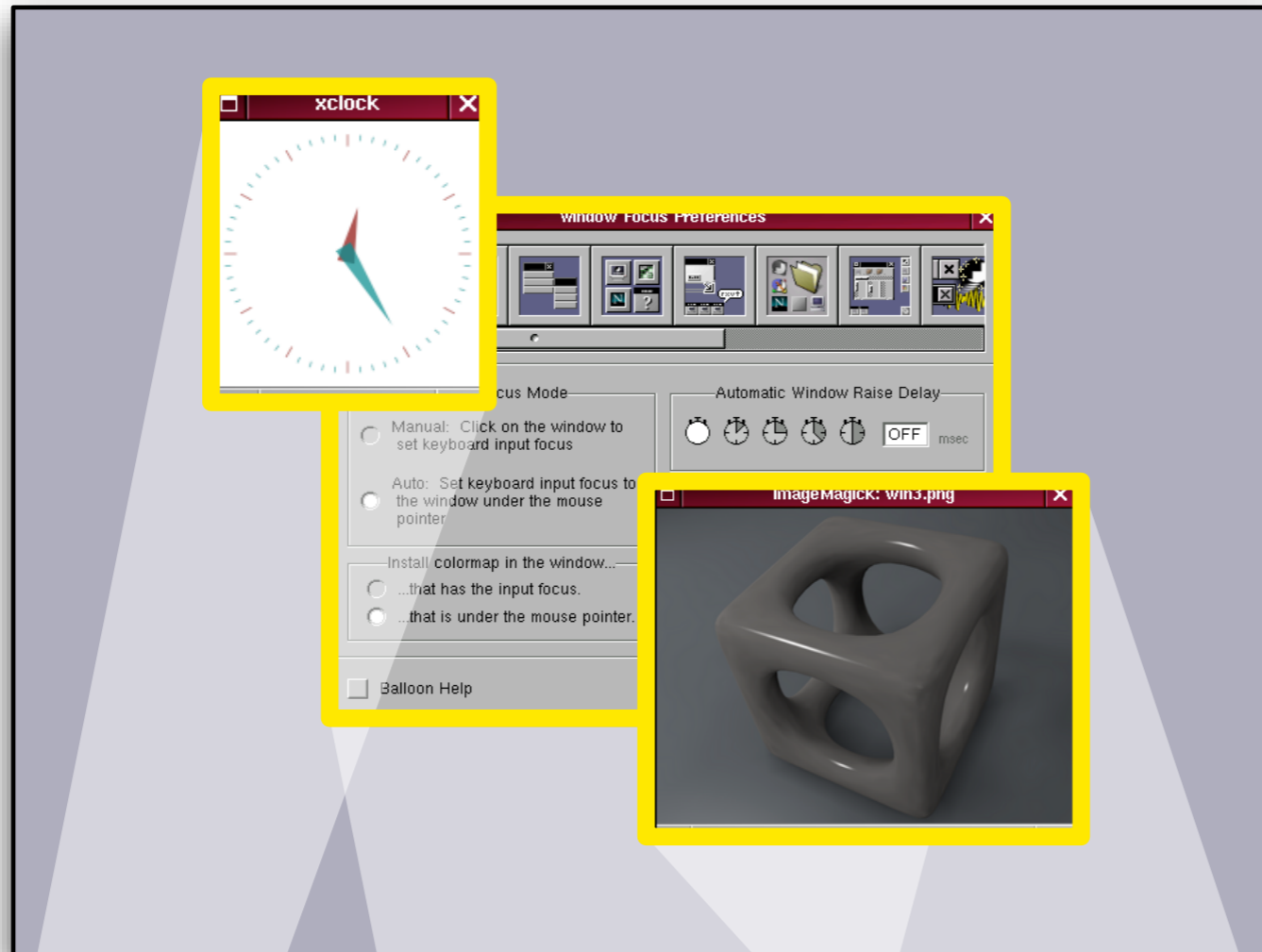

Views

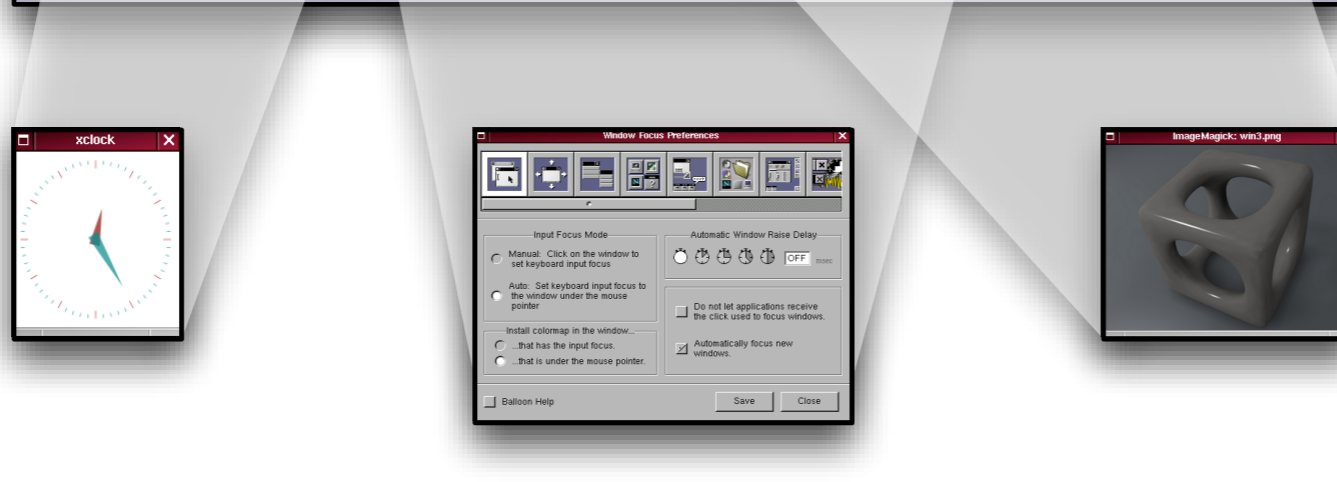

Buffers

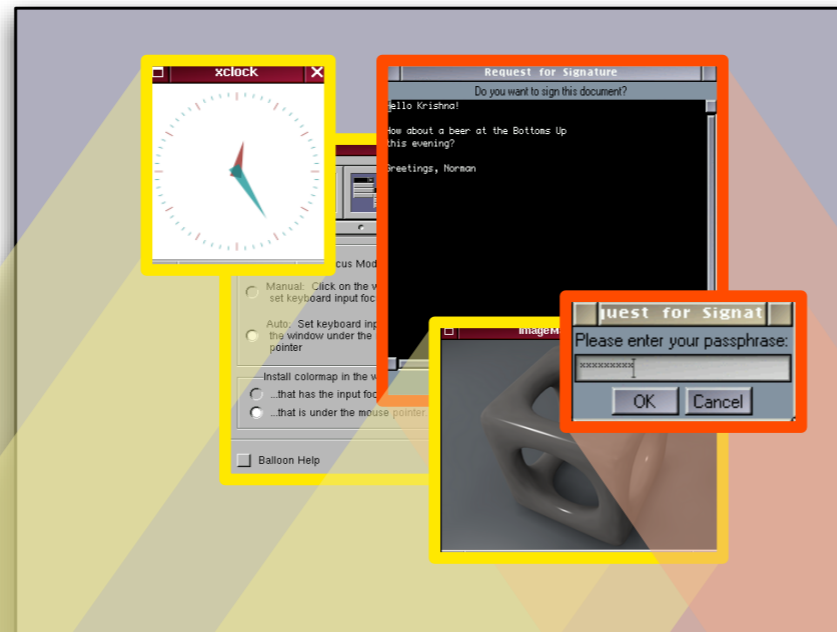

Views

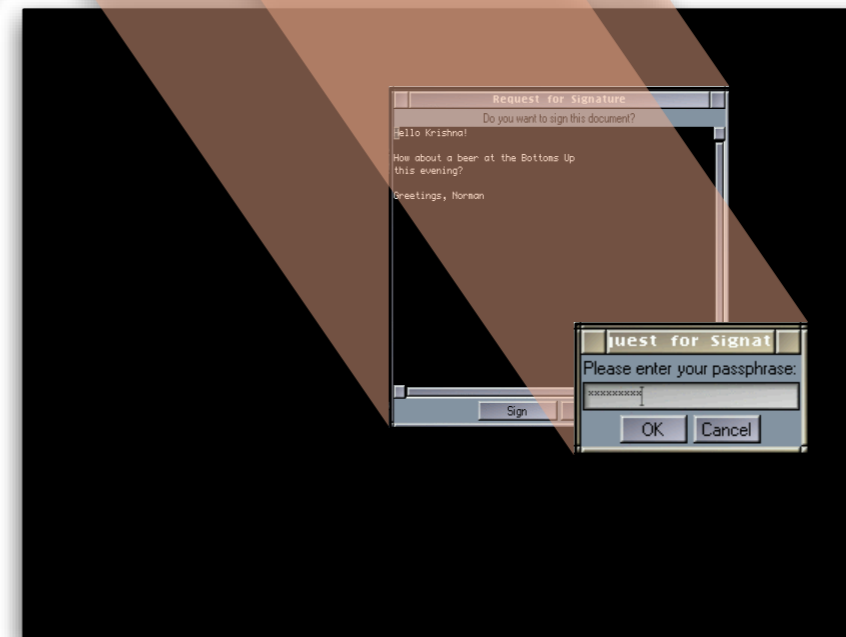
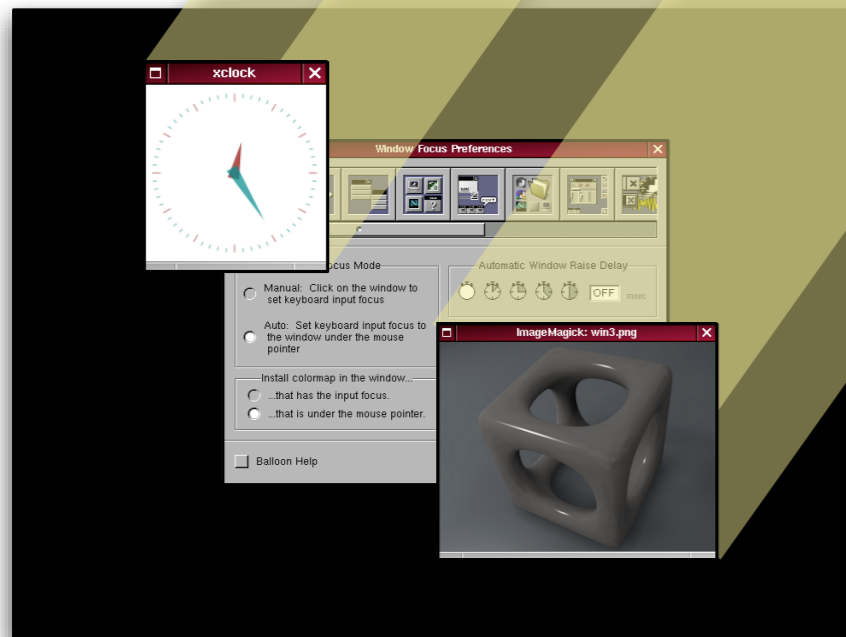

Buffers

NITPICKER IN ACTION

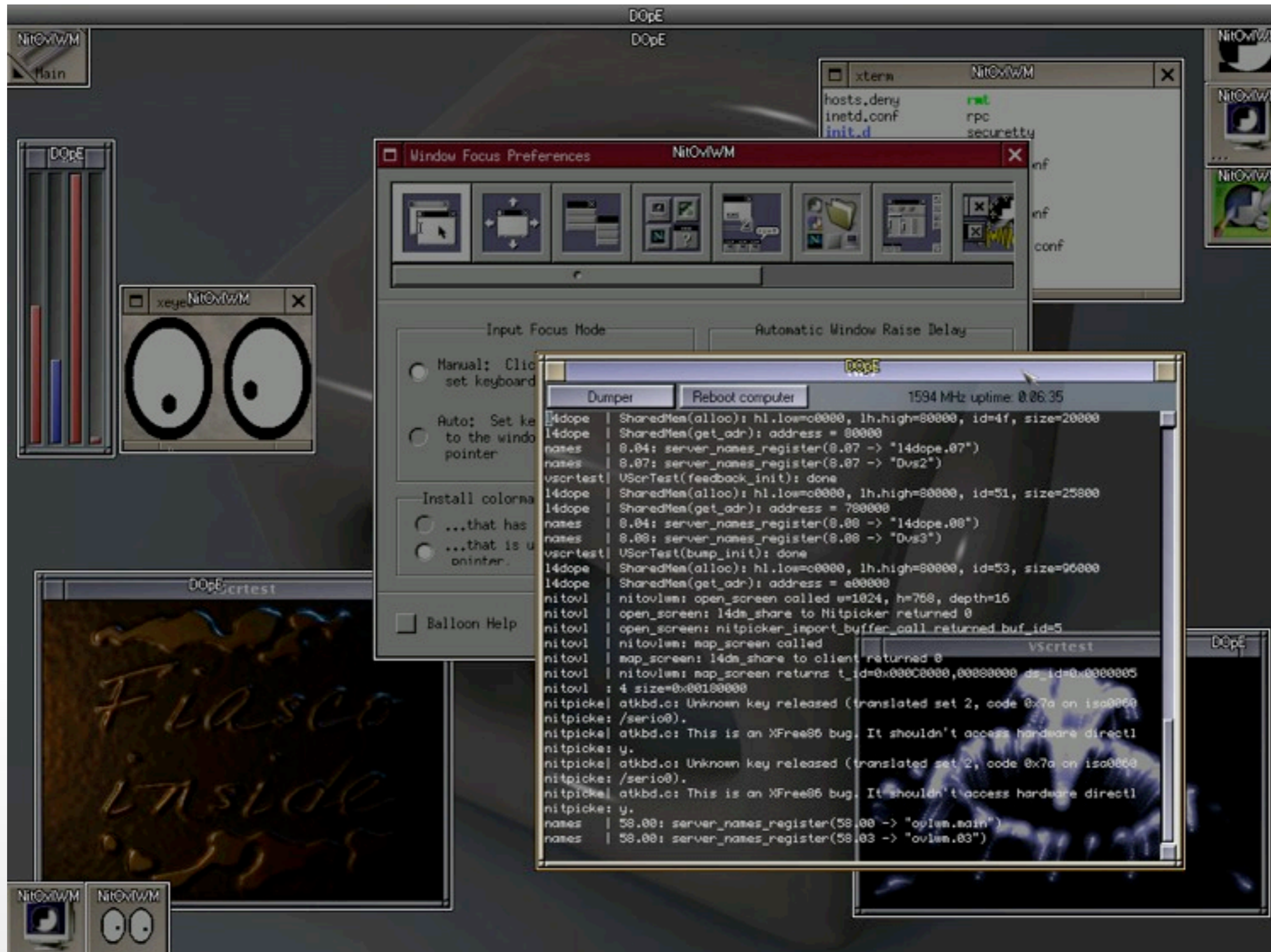

DEMO

- Secure reuse of untrusted legacy infrastructure
- Split apps + OS services for smaller TCB
- Nizza secure system architecture:
 - Strong isolation
 - Application-specific TCBs
 - Legacy Reuse
 - Trusted Wrapper

- Next year, January 8th:
 - Lecture on „*Trusted Computing*“:
 - Where does VPFS store its secrets?
 - How to prevent tampering with stored data?
 - How to trust in what Nitpicker shows on screen?
- Also on January 8th:
 - Practical exercise, room E069

- [1] <http://www.heise.de/newsticker/Month-of-Kernel-Bugs-Ein-Zwischenstand--/meldung/81454>
- [2] <http://projects.info-pull.com/mokb/>
- [3] Carsten Weinhold and Hermann Härtig, „VPFS: Building a Virtual Private File System with a Small Trusted Computing Base“, Proceedings of the 3rd ACM SIGOPS/EuroSys European Conference on Computer Systems, April 2008, Glasgow, Scotland UK
- [4] Carsten Weinhold and Hermann Härtig, „jVPFS: Adding Robustness to a Secure Stacked File System with Untrusted Local Storage Components“, Proceedings of the 2011 USENIX Annual Technical Conference, Portland, OR, USA, June 2011
- [5] Norman Feske and Christian Helmuth, „A Nitpicker's guide to a minimal-complexity secure GUI“, ACSAC '05: Proceedings of the 21st Annual Computer Security Applications Conference, 2005, Washington, DC, USA
- [6] Christian Helmuth, Alexander Warg, Norman Feske, „Mikro-SINA - Hands-on Experiences with the Nizza Security Architecture“, D.A.CH Security 2005, 2005, Darmstadt, Germany
- [7] <http://support.apple.com/kb/HT4013>
- [8] <http://support.apple.com/kb/HT3754>
- [9] <http://jailbreakme.com>