

Real-Time Systems

Hermann Härtig

Real-Time Communication

(following Kopetz, Liu, Schönberg, Löser)

23/01/13

Contents

- Overview
- IO Busses: PCI
- Networks as schedulable resources:
Priority / Time-Driven / Weighted Round Robin
 - Priority - Based Field: CAN/Token Ring
 - Weighted Round Robin in Wide Area
 - Ethernet in RT:
 - Shaping
 - TT-Ethernet

General Scenario

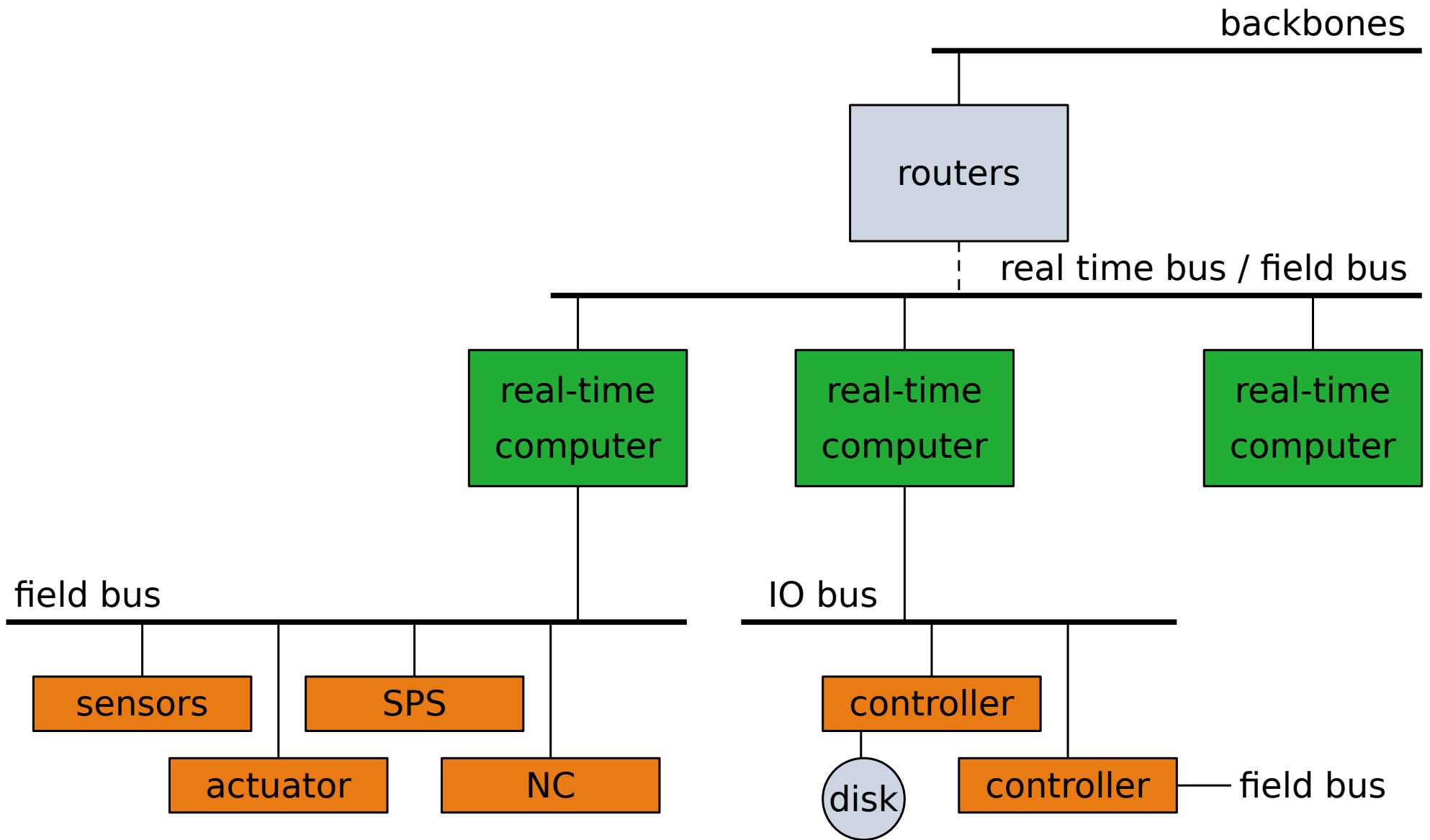

Purpose of a real-time network

- Deliver communication services to the requesting nodes reliably, securely, efficiently and **timely**
 - lower bound for bandwidth
 - upper bound for latency and jitter

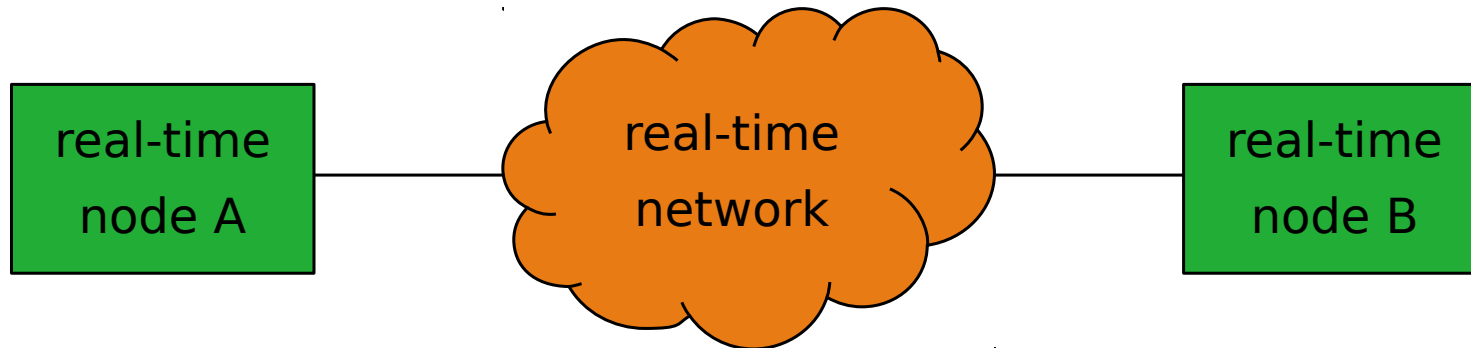

Typical requirements

- Short data in control applications
Large data in media applications
- Short periods (ms)
 - monitoring, feedback control
- Fast aperiodic (ms)
 - alarms
- Non real-time data
 - configuration, logs
- Multicast
- Predictability in the presence of faults

Intra-Node communication: IO bus (PCI)

- All data transfers share the memory bus
 - Memory bus conflicts
 - PCI devices start transfers when data is available
 - CPU-Memory-accesses are influenced by PCI devices
 - applications are slowed down by external load

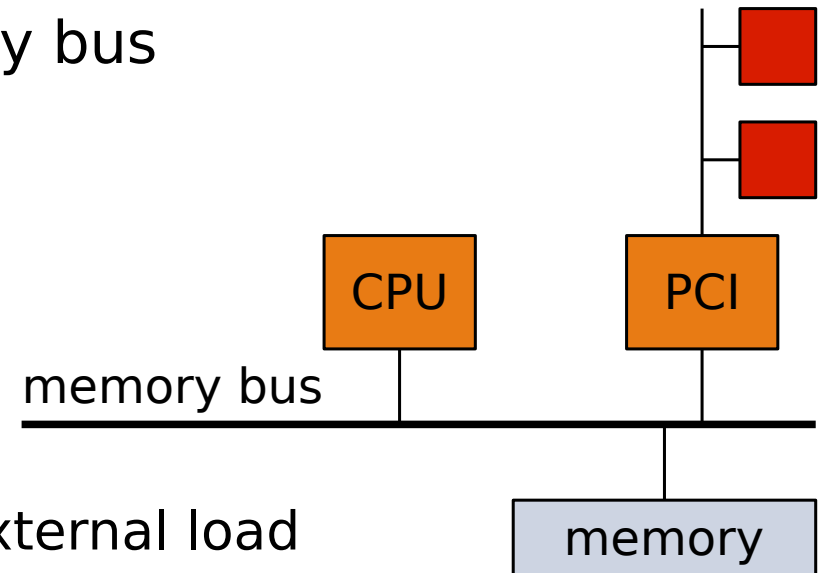

- Slowdown factor F : $(ET: \text{execution time})$
 $ET \text{ under external load} / ET \text{ without any external load}$
 - application-specific depends on memory access pattern
 - obtained by measurements attempts to statically predict

Some measurements

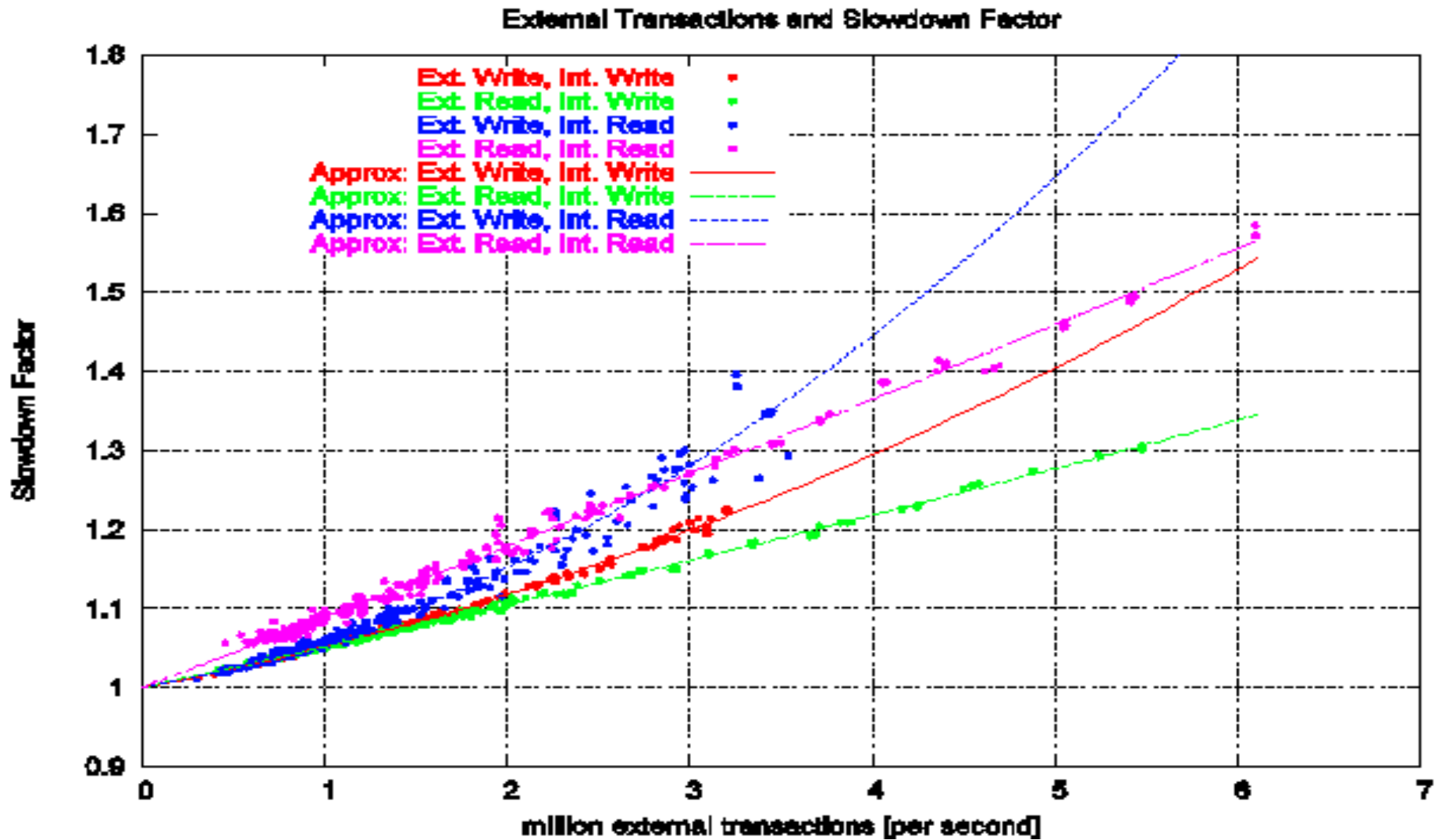

Source: Dissertation Sebastian Schönberg (see our Web-Pages)

Intra-Node communication: PCI bus

- PCI bus specification does not prevent real-time implementation
 - Arbitration responsible for granting bus to devices
 - Current implementations use round-robin arbitration
- Telecom Systems
 - PCI bus for control data
 - TDMA bus for real-time data

Intra-Node communication: PCI bus

Alternatives (research proposals)

- real-time capable PCI bus arbiter
 - Assign individual share of the PCI bus to devices
 - Enforce reservation
 - Give unused bandwidth to time-sharing devices
- RT-Bridges
 - Between device and bus
 - Enforces bandwidth restriction

Memory Bus in MultiCore systems:
active area of research

Networks as schedulable resources

- Analogous to CPU scheduling:
 - time driven
 - priority driven
 - (Weighted Round Robin)
- Analogy:
 - WCET: Amount of traffic / message transmission time
 - Periodic tasks: periodic messages
messages are usually non-preemptive !!
 - Deadline: max delay
 - Admission: connection establishment
 - Schedulers in switches or distributed on nodes

Examples

- Fieldbus:
 - CAN, Token Ring: priority based scheduler
 - TTP/Flexray/TT-Ethernet: time driven scheduling
- Switch:
 - (Delay EDD)
 - Weighted Round Robin
(neither priority nor time driven !)

Intra-Node communication: field busses

- Situation is moving
 - Smart sensors, actors
 - Wireless lans

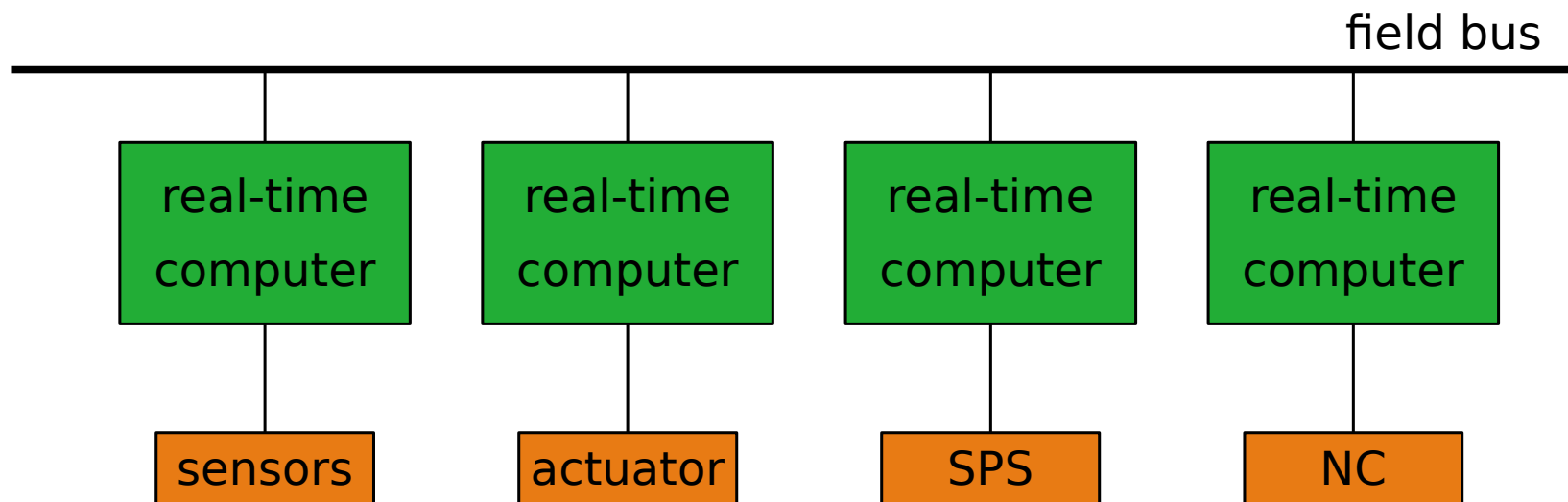

Fieldbus

- Networks for process control, factory automation, cars, avionics, X-by-wire, embedded applications

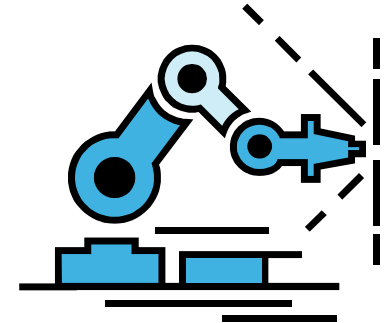

- Networks are typically called fieldbusses:
 - collapsed network stacks (application services access the data link directly)
 - real-time transport
 - short application messages (no need for fragmentation and reassembling)
 - often a bus, hence a single broadcast domain, no routing



Image source: Microsoft Clip-Art Gallery

Multiple access to shared medium

- CSMA/CD shared ethernet
- CSMA/BA with priorities (CAN)
- Token Ring with priorities
- TDMA

CAN - controller area network

- Bosch GmbH, Version 2.0 released in 1991
 - ISO Standards 11519 (94) and 11898 (95)
 - used in automotive industry, process control, manufacturing automation, embedded application domains
 - cost-effective
-
- CSMA/BA:
carrier sense multiple access/bitwise arbitration

Bus arbitration with CAN (priority based)

- CSMA/BA (carrier sense multiple access/bitwise arbitration)
- Bit-wise collision resolution using message identifiers, sent from HSB to LSB
- Wired "and", implemented with bus drivers
 - 0 - Dominant level
 - 1 - Recessive level

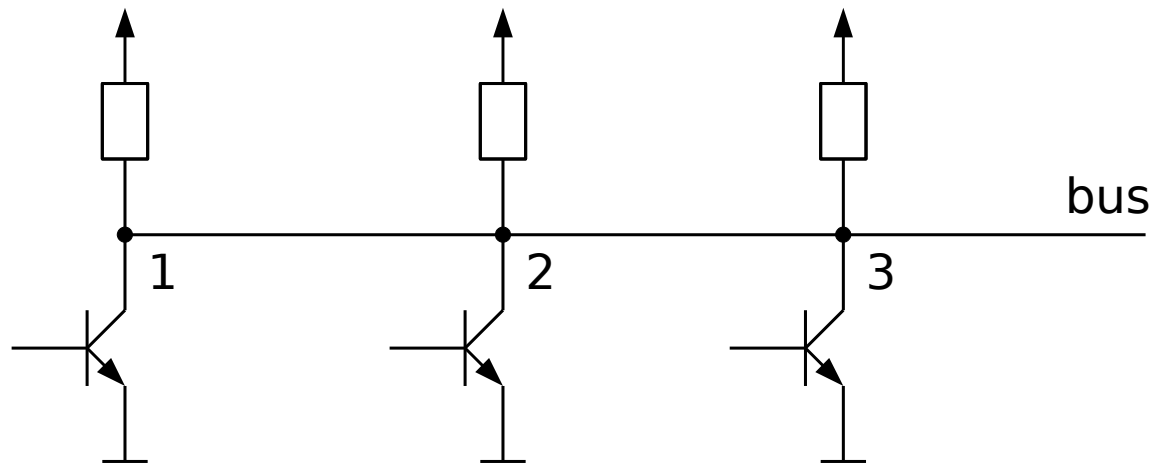

- Node stops if a "0" is seen when sending a "1"

CAN message



- Bit stuffing to allow synchronization at bit level
 - after 4 '0's or 4 '1's: dummy 1 or 0
- Transmission time of a message in bit-times:

$$C = 13 + 34 + \text{databits} + (34 + \text{databits} - 1) / 4$$

CAN performance

- Transmission rate from 5KBit/s to 1MBit/s
- Bit-synchronized bus access
- Bus length depends on transmission rate
 - 40m with 1MBit/s, 1000 with 50KBit/s
- transmission rate increases with shorter busses
... or with increased speed of light

- 2048 priorities (11 Bit) in version A,
>500 Mio priorities (29 Bit) in version B
- Short messages (0-8 Byte)
- Efficiency depends on msg length: 0%..47%

Medium access control using a token ring

- Messages follow a logical ring
- Token required as permission to send (round robin scheduling)

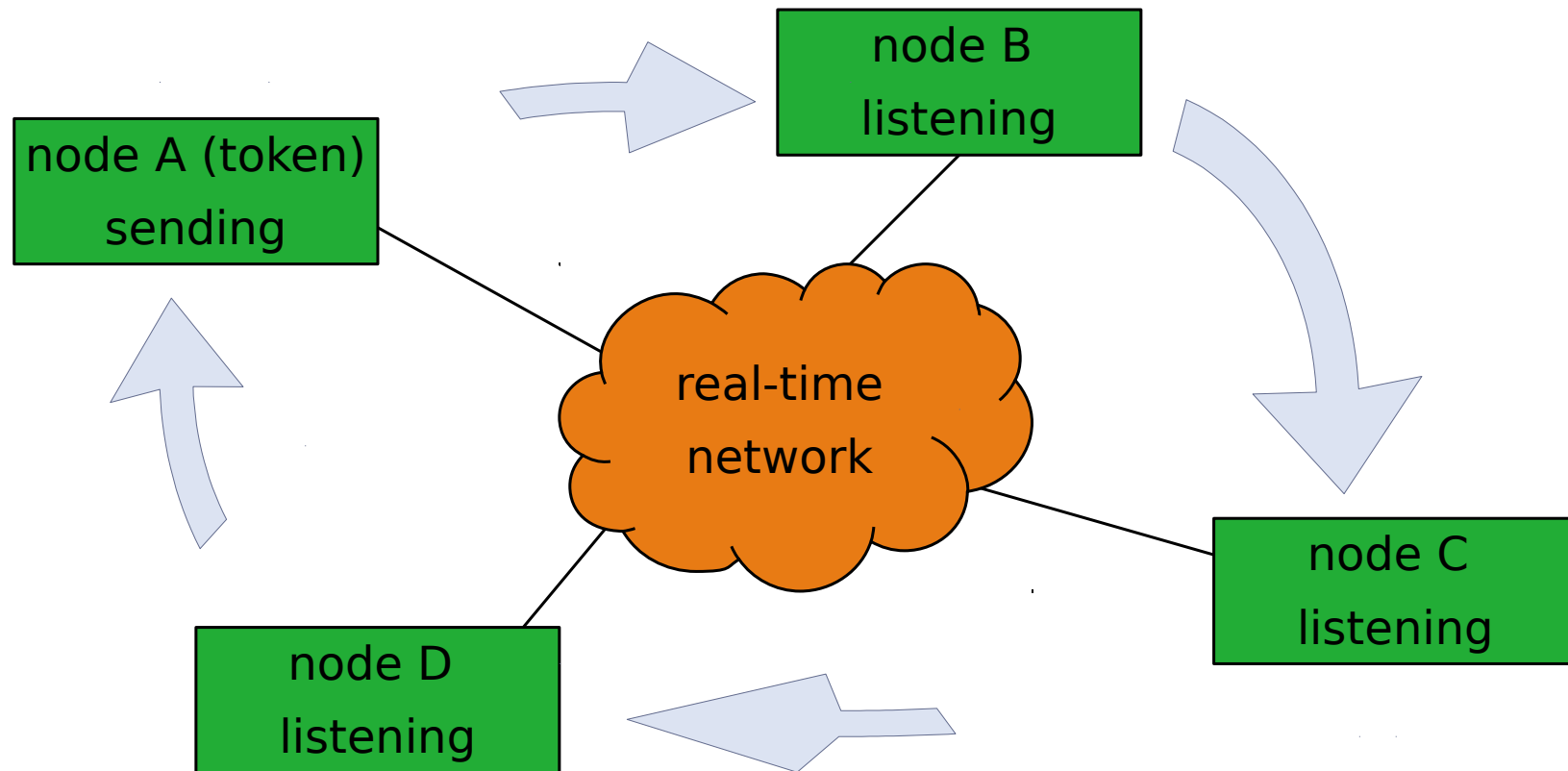

Token Ring with priorities (simplified!!)

- Frames: Data, Token
- **Token:** Token Priority field, Reservation Priority field
- **Data:** Data field, Reservation Priority field
- Token can be taken only, if Token Priority is lower than priority field in outgoing data frame
- Reservation Priority is set to highest priority of waiting messages that are passed by packet
- Upon arrival of a data frame at its sender, a token is generated with priority is set to the data frame's priority reservation field

Example

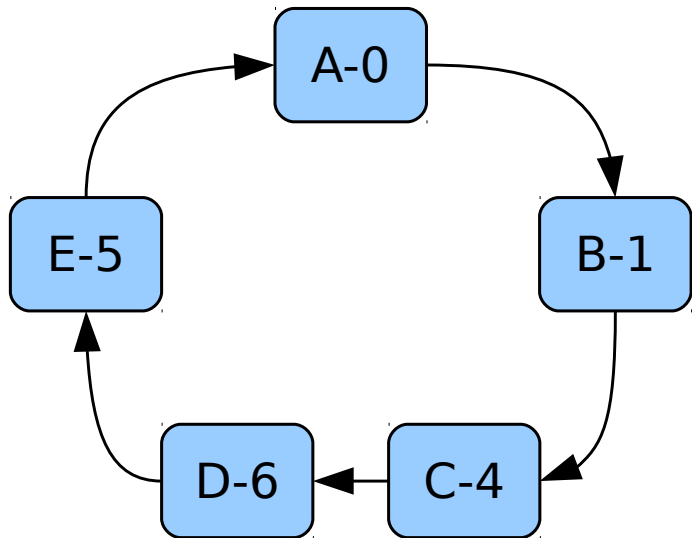

Notation:

„Data, ResPrio“

„T-Prio, ResPrio“

A,B,C,D want to send.

Token T-0,0 arrives at A

High number → high prio

A	sends:	Data,0
B	sets frame to:	Data,1
C	sets frame to:	Data, 4
D	sets frame to:	Data, 6
E	does nothing	
A	creates token:	T-6, 0
B	waits, sets ResPrio:	T-6, 1
C	waits, sets ResPrio:	T-6, 4
D	claims token, sends:	Data, 4
D	receives Data, creates token:	T-4, 0
C	sends, B sends, B creates token:	T-0, 0

More on Token Ring

- Not necessarily a strict ring
- Functional Parameters
 - Maximum token holding time at each node
 - Rings: resulting maximum token rotation time
- Problems:
 - lost tokens
 - duplicated tokens

Time division multiple access (TDMA)

- Divide Time periodically into Slots
- Allocate Slots
- Slots:
 - Cooperative (BUT: failures)
 - enforced

Kopetz: event vs. time triggered

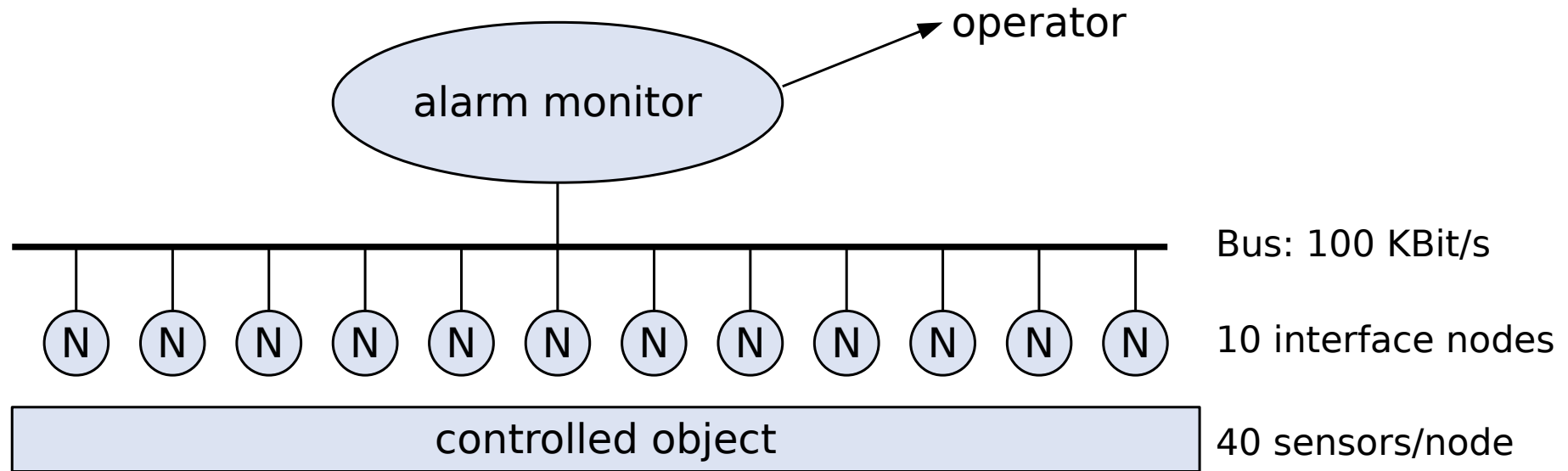

- Each node supervises 40 alarm conditions and sends messages (as soon as possible)
- Deadline: 100 ms to notify operator
- Communication bandwidth: 100 kbits/second

Kopetz: event triggered (ex. CAN)

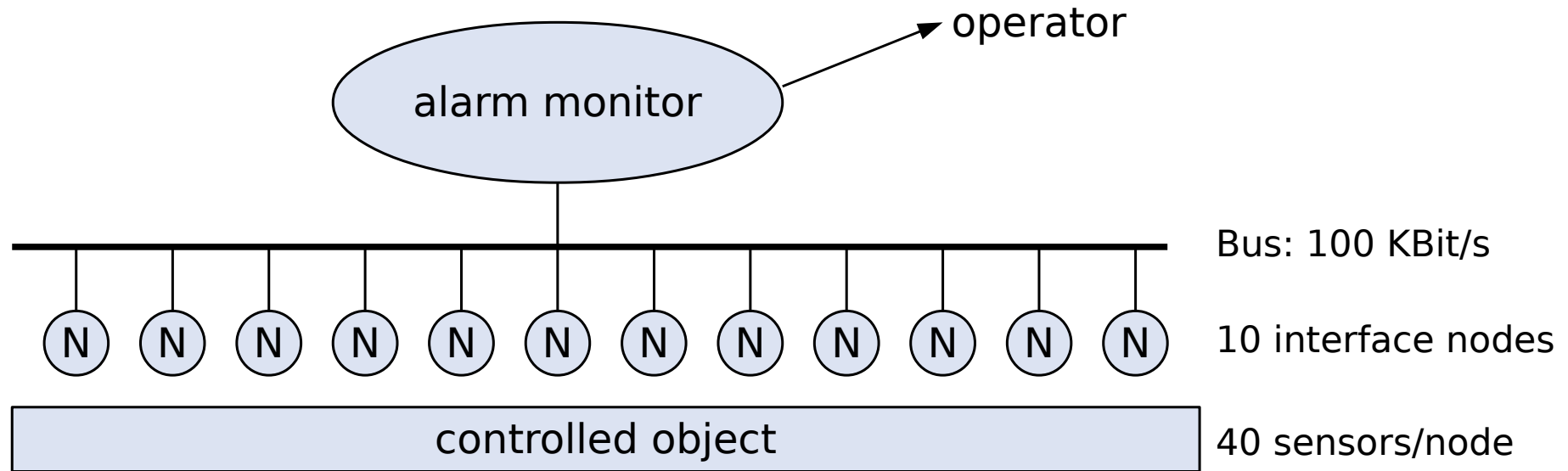

- Send message as soon as alarm condition is seen
size = alarm name (8 Bit) + CAN overhead (44+4 Bit) = 56 Bit
- allows 180 messages within deadline of 100ms
- worst case requirement: 400 messages ...

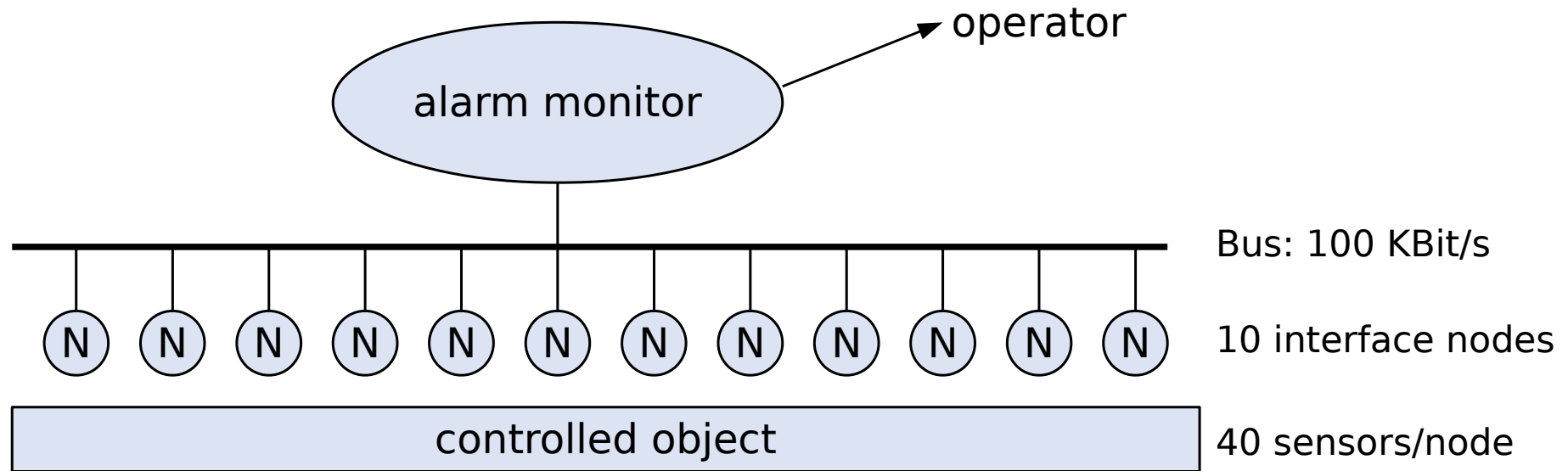

- Each node sends state message every 100ms
size: Data field (40 Bit) + overhead (44) + gap (4) = 88 Bit
- allows 110 messages within 100ms period
- but, just 10 required!
 - i.e. 10 % of bandwidth

TT Ethernet as an example for TDMA

- Participants request slots
- Switch enforces slots
- Based on sparse time (determinism)

- See separate slides by Kopetz



Principles

- “find” connection (reservations)
- determine local properties at each node of connection depending on node-local scheduler
- add up delays
- take care for jitter (provide buffer, traffic shapers)

Example in this lecture: Weighted Round Robin

Others:

- Static
- Dynamic, EDF: e.g., Delay-EDD “Service Discipline”

See text books

Principle:

- Message passes multiple nodes from source to dest.
During set up (admission) a *weight(wt)* is assigned to each input buffer of all involved switch
- Scheduler at each node
 - Visits input buffers in round robin
 - processes *wt* number of units of messages at each buffer per round

Scheduling example: Weighted Round Robin

Jane Liu

Messages:

- e_i max „length“ of message in “units”
- p_i Period: minimum inter-arrival time
- ρ number of hops
nodes passed by message from
source to destination

how to guarantee

- bandwidth and
- end-to-end delay

Scheduling example: Weighted Round Robin

Jane Liu

Nodes:

- wt_i each connection is given wt_i slots per round.
- RL round length (switch design parameter)
- e_i max „length“ of message in units
if $wt_i=1 \rightarrow e_i$ rounds at the switch are needed

$$\Sigma wt_i \leq RL$$

Round lengths ?

Weights?

Delay? Per Node, end to end?

Some Calculations:

Delay per Node:

$$RL * \lceil e_i / wt_i \rceil$$

RL is bound by delay guarantees of Node for example, to guarantee that messages are transmitted within a period:

$$RL \leq \min p_i$$

$$wt_i \geq \lceil e_i / \lfloor p_i / RL \rfloor \rceil$$

end to end delay (pipelined “execution”):

$$\left(\lceil e_i / wt_i \rceil + \rho - 1 \right) * RL$$

Summary

- Field busses
 - Scheduling analysis analog to processors
 - Use time driven / static priority / table based scheduling
- Switched LANs
- WANs
 - Dynamic
 - Use local scheduling disciplines in switches/routes to enforce system wide behaviour
 - Admission for connections required