



**TECHNISCHE
UNIVERSITÄT
DRESDEN**

Department of Computer Science Institute of System Architecture, Operating Systems Group

SECURITY ARCHITECTURES

CARSTEN WEINHOLD



CLASSICAL ARCHITECTURES

- Isolation in commodity OSes for PCs:
 - Based on user accounts
 - Same privileges for all apps
 - No isolation within applications
 - Permissive interfaces (e.g., ptrace to manipulate other address spaces)

KERNEL ATTACK VECTOR

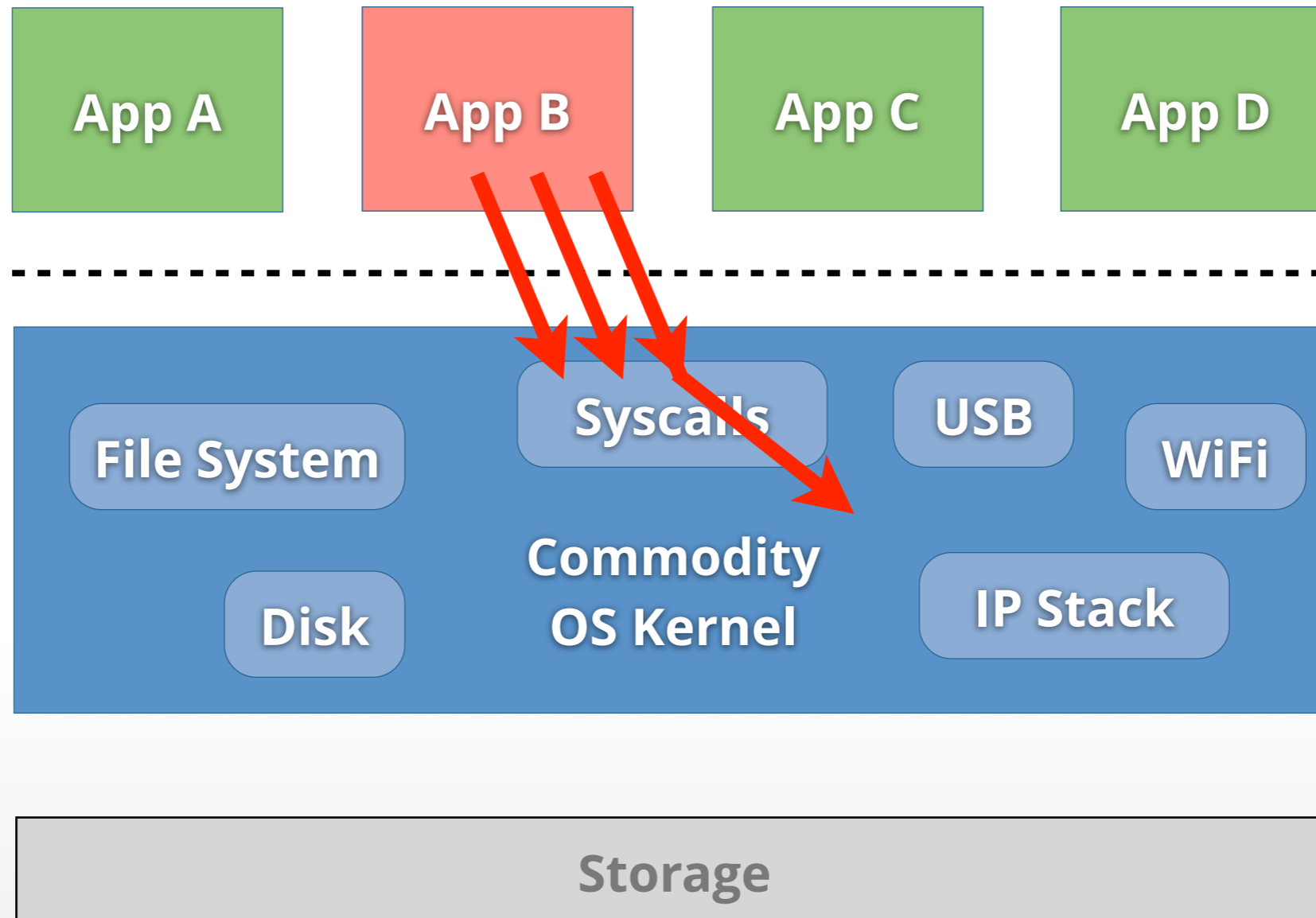

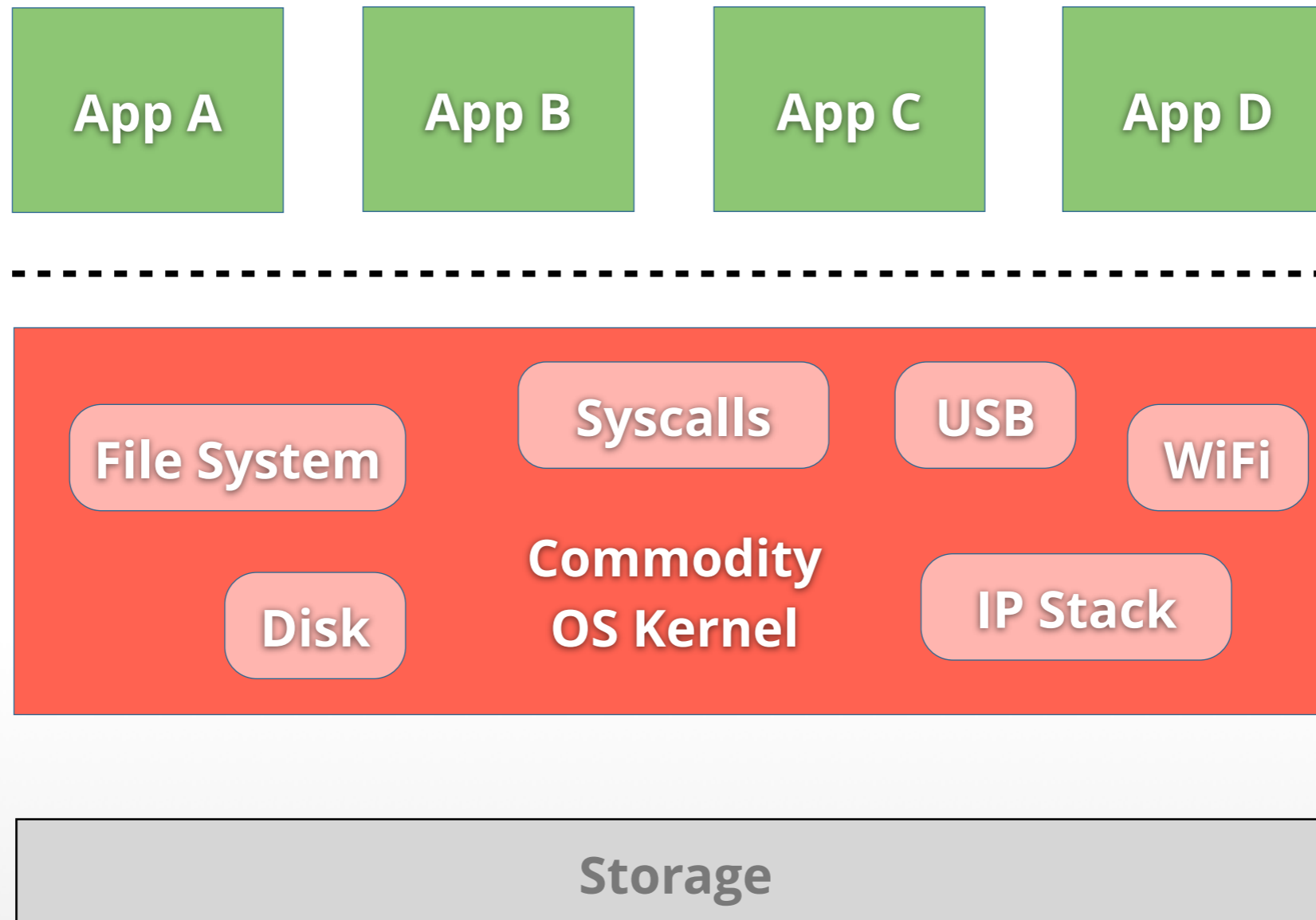

KERNEL ATTACK VECTOR

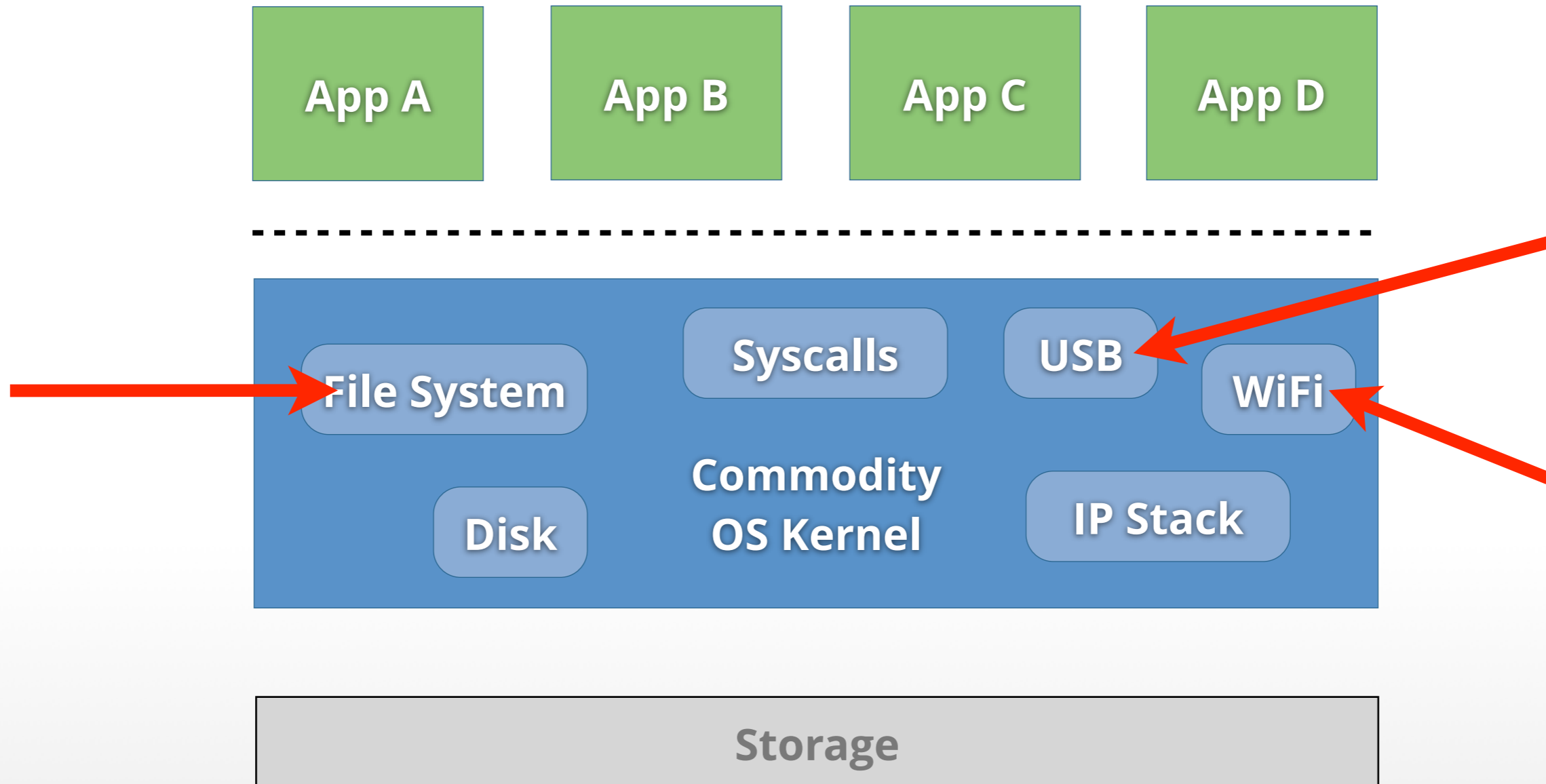

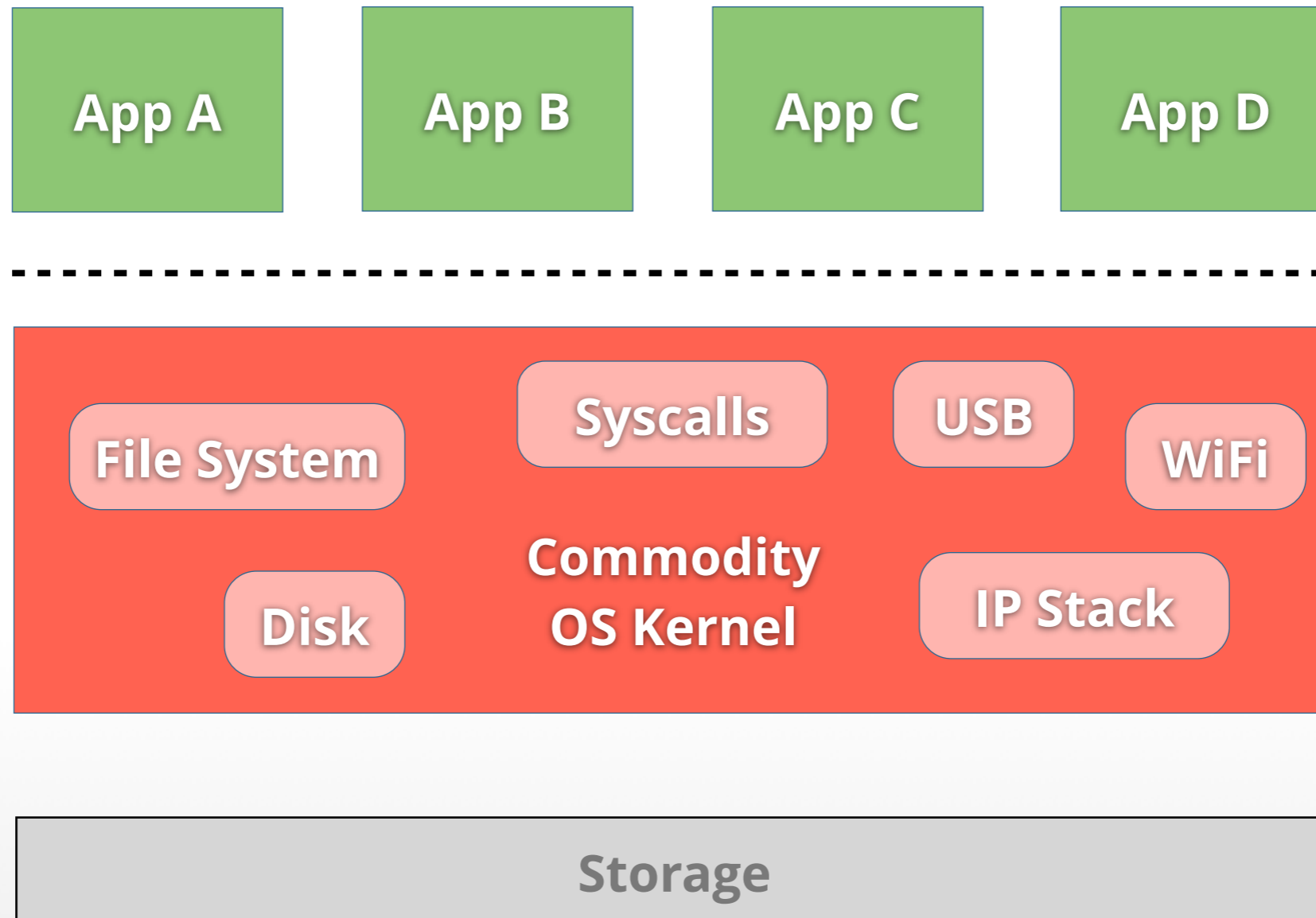

- Isolation in commodity OSes for PCs:
 - Based on user accounts
 - Same privileges for all apps
 - No isolation within applications
 - Permissive interfaces (e.g., ptrace to manipulate other address spaces)
- Efforts to restrict privileges:
 - SELinux, AppArmor, Seatbelt, ...

- Separate computers
- Applications and data physically isolated
- Effective, but ...
 - Higher costs
 - Needs more space
 - Inconvenient
 - Exposed to network

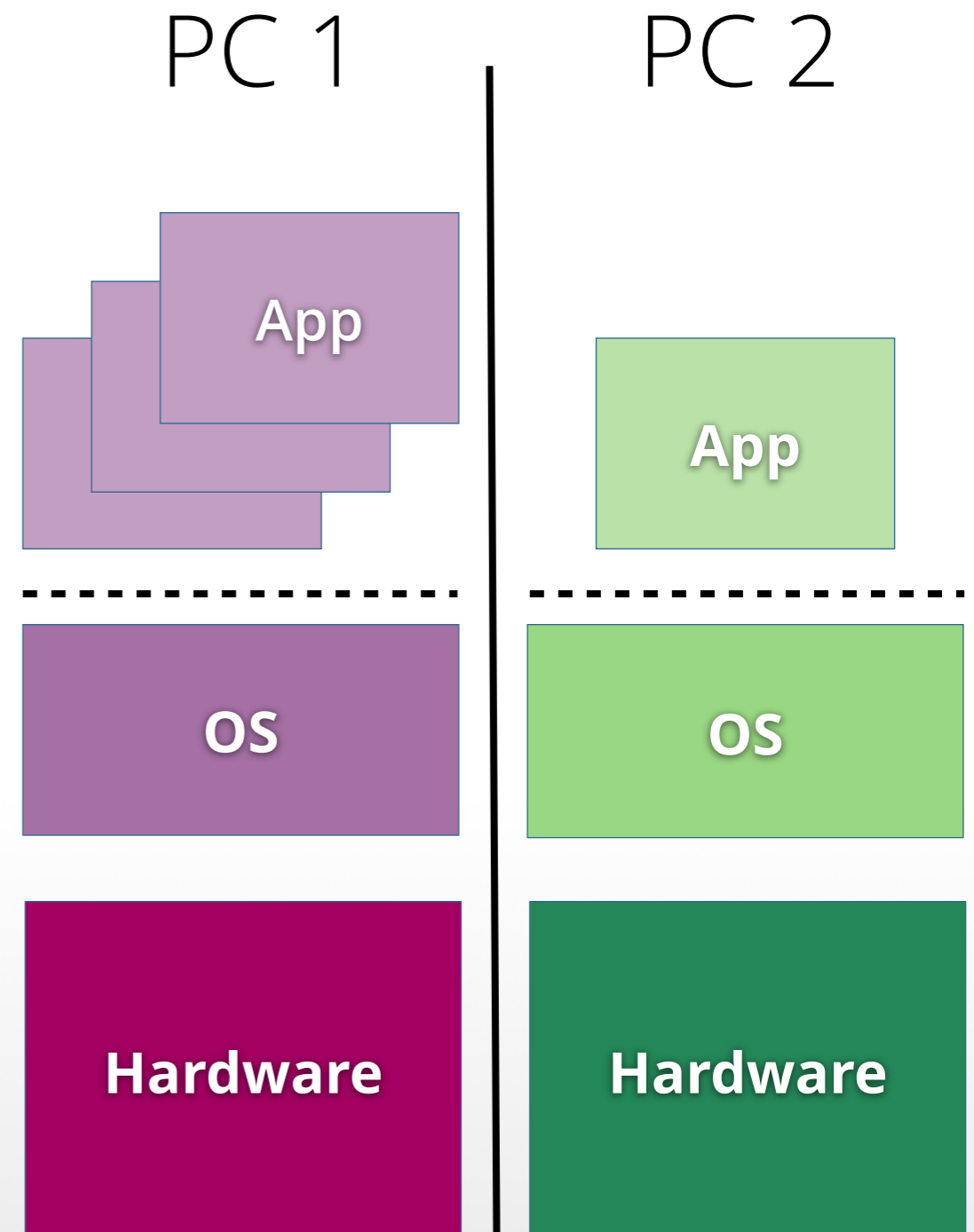

- Multiple VMs, OSes
- Isolation enforced by virtualization layer
- Saves space, energy, maintenance effort
- But still ...
 - Switching between VMs is inconvenient
 - Even more code

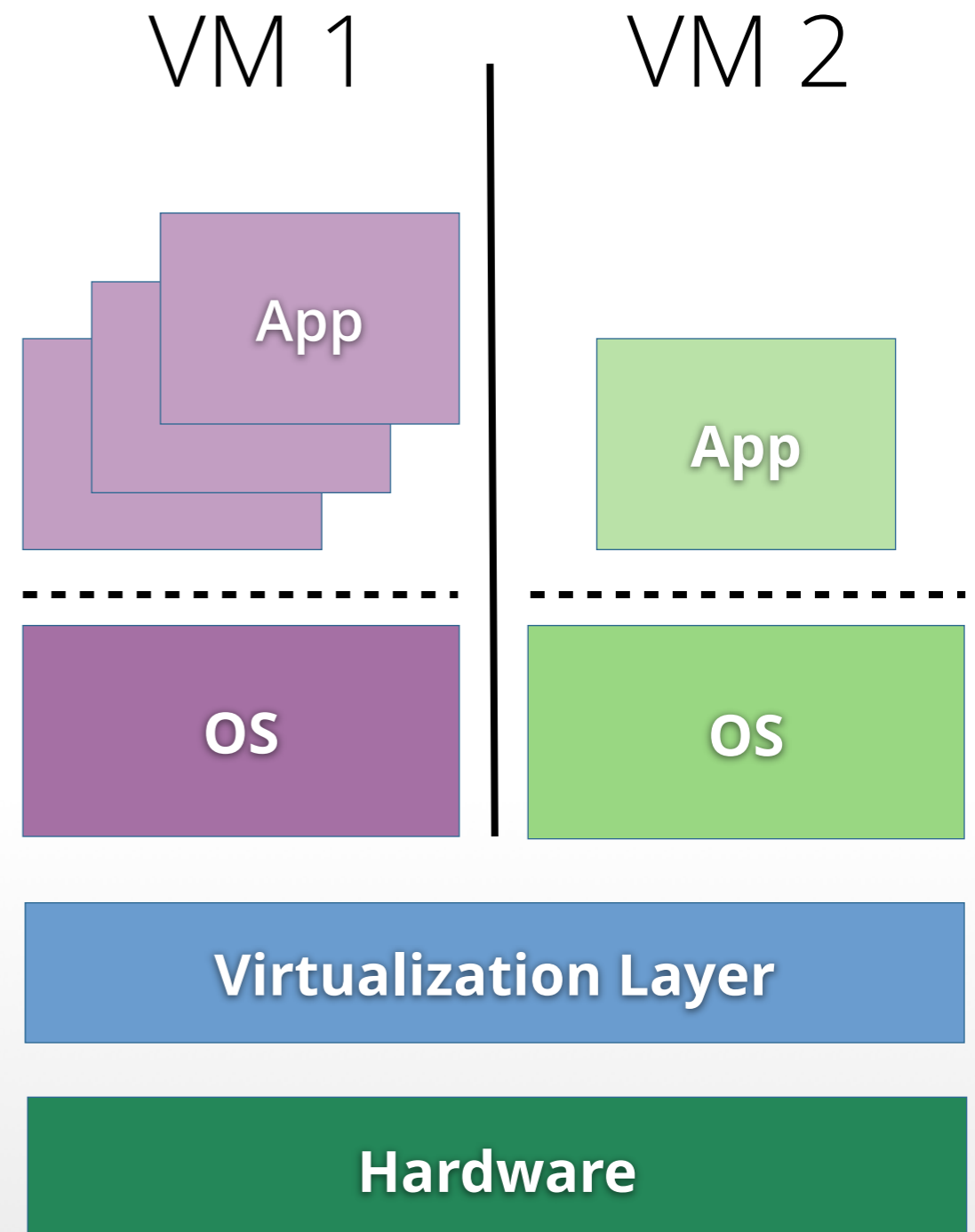

- Huge code bases remain
- Applications still the same
- Many targets to attack:
 - Applications, libraries, commodity OSes
 - Virus scanner, firewall, ...
 - Virtualization layer
- High overhead for many VMs

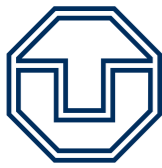

SECURITY ARCHITECTURES

- Protect the user's data
- Secure applications that process data
- Acknowledge different kinds of trust, e.g.:
 - Application **A** trusted to handle its own data, but not the files of application **B**
 - OS trusted to store data, but not to see it
- Identify and secure **TCB**: the **T**rusted **C**omputing **B**ase

- To improve security: Reduce size of TCB
= smaller attack surface
- First (incomplete) idea:
 - Remove huge legacy OS from TCB
 - Port application to microkernel-based multi-server OS
 - Remove unneeded libc backends, etc.
 - Possible approaches discussed in lecture on „Legacy Reuse“

NIZZA ARCHITECTURE

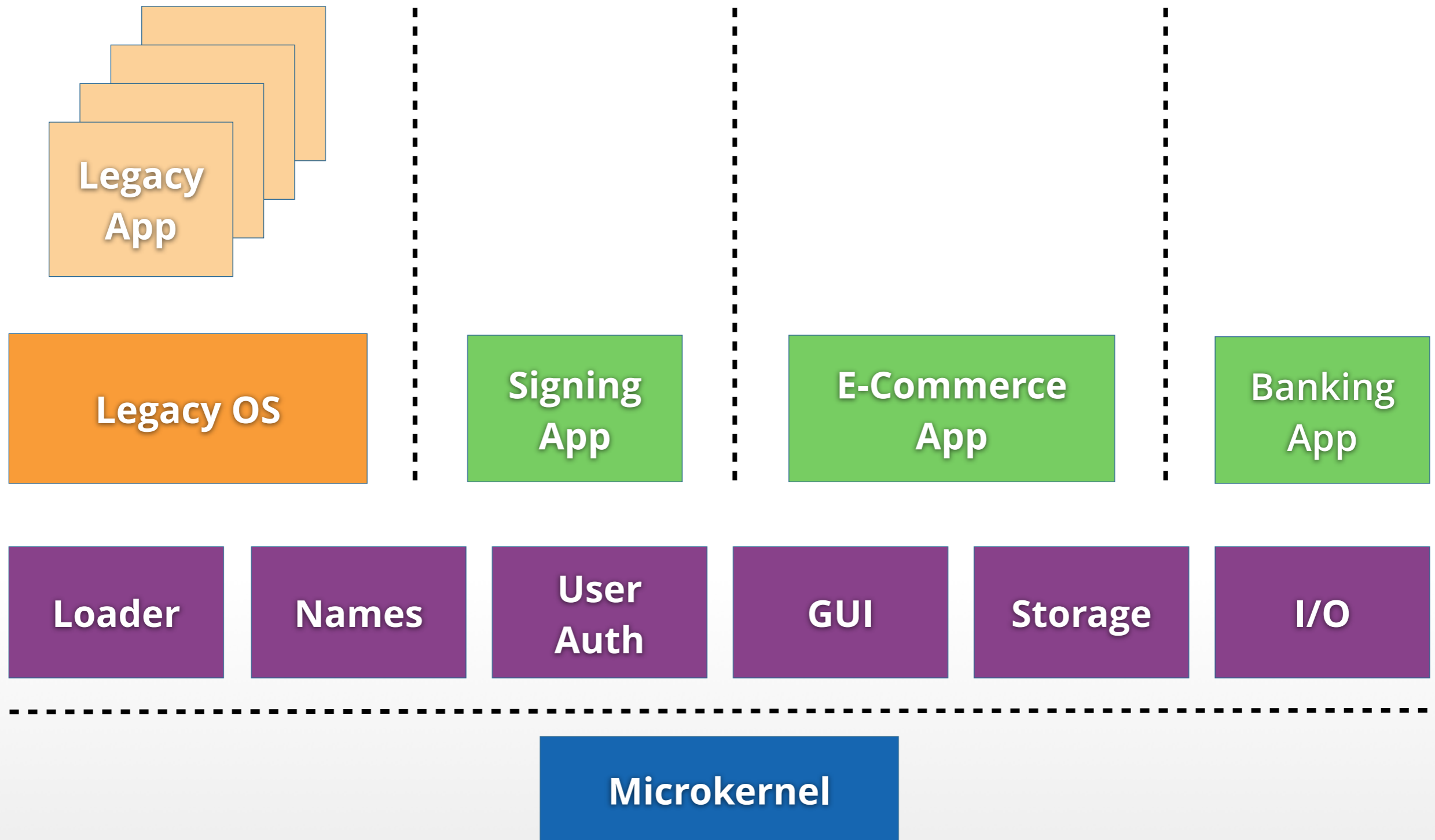

Nizza architecture: fundamental concepts:

- Strong isolation
- Application-specific TCBs
- Legacy reuse
- Trusted wrappers
- Trusted computing

- Reflects **Principle of Least Privilege**
- TCB of an application includes only components its security relies upon
- TCB does not include unrelated applications, services, libraries

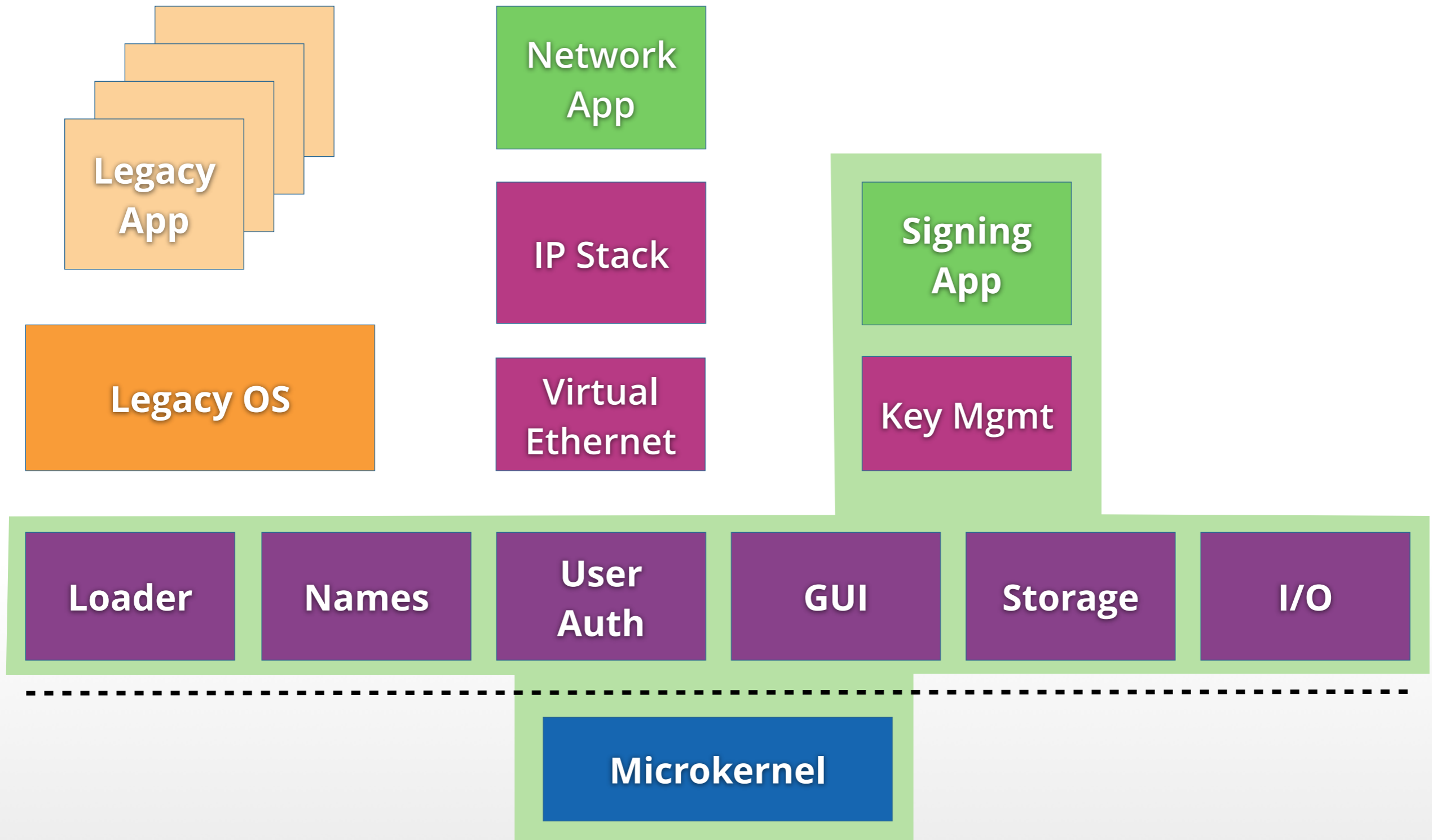

- Reflects **Principle of Least Privilege**
- TCB of an application includes only components its security relies upon
- TCB does not include unrelated applications, services, libraries
- **Mechanisms:**
 - Address spaces + IPC control for isolation
 - Well-defined interfaces

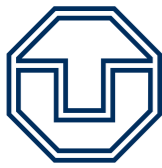

SPLITTING COMPONENTS

- Problems with porting applications:
 - Dependencies need to be satisfied
 - Can be complex, require lots of code
 - Stripped down applications may lack functionality / usability
- Better idea: split application
 - Make only security-critical parts run on microkernel-based OS
 - Parts of application removed from TCB

Digitally signed e-mails, what's critical?

- Handling of signature keys
- Requesting passphrase to unlock signature key
- Presenting e-mail message:
 - Before sending: „**What You See Is What You Sign**“
 - After receiving: verify signature, identify sender

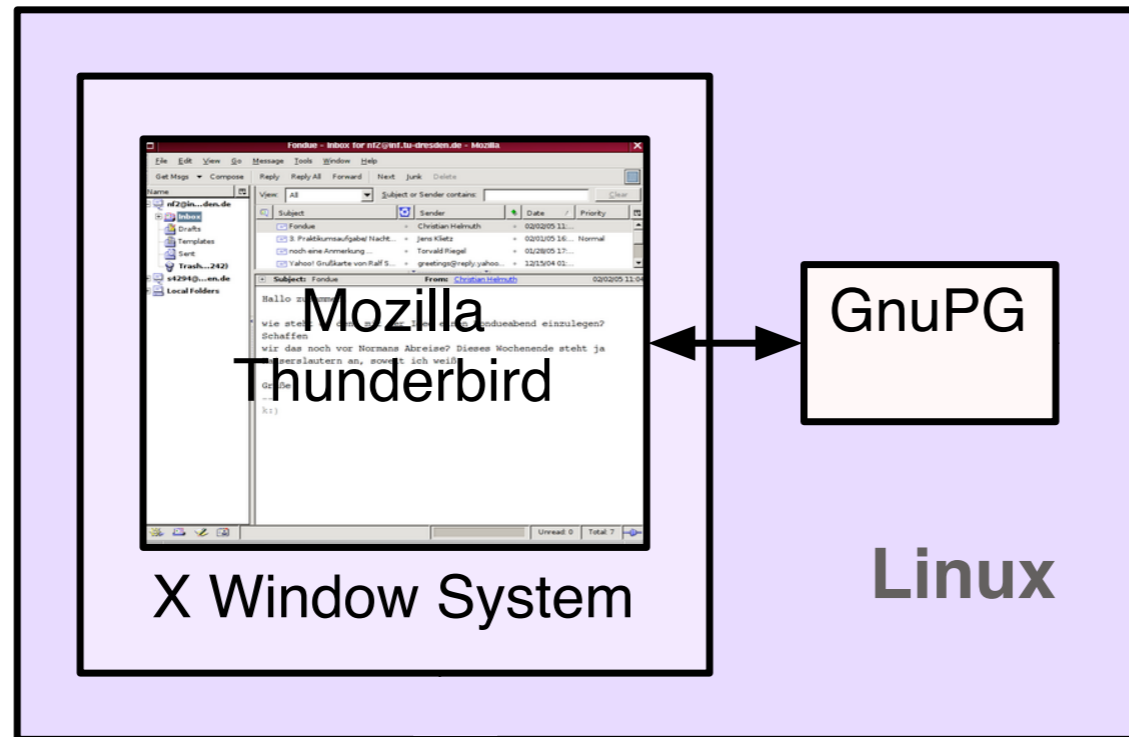

Image source: [5]

SPLIT EMAIL APP

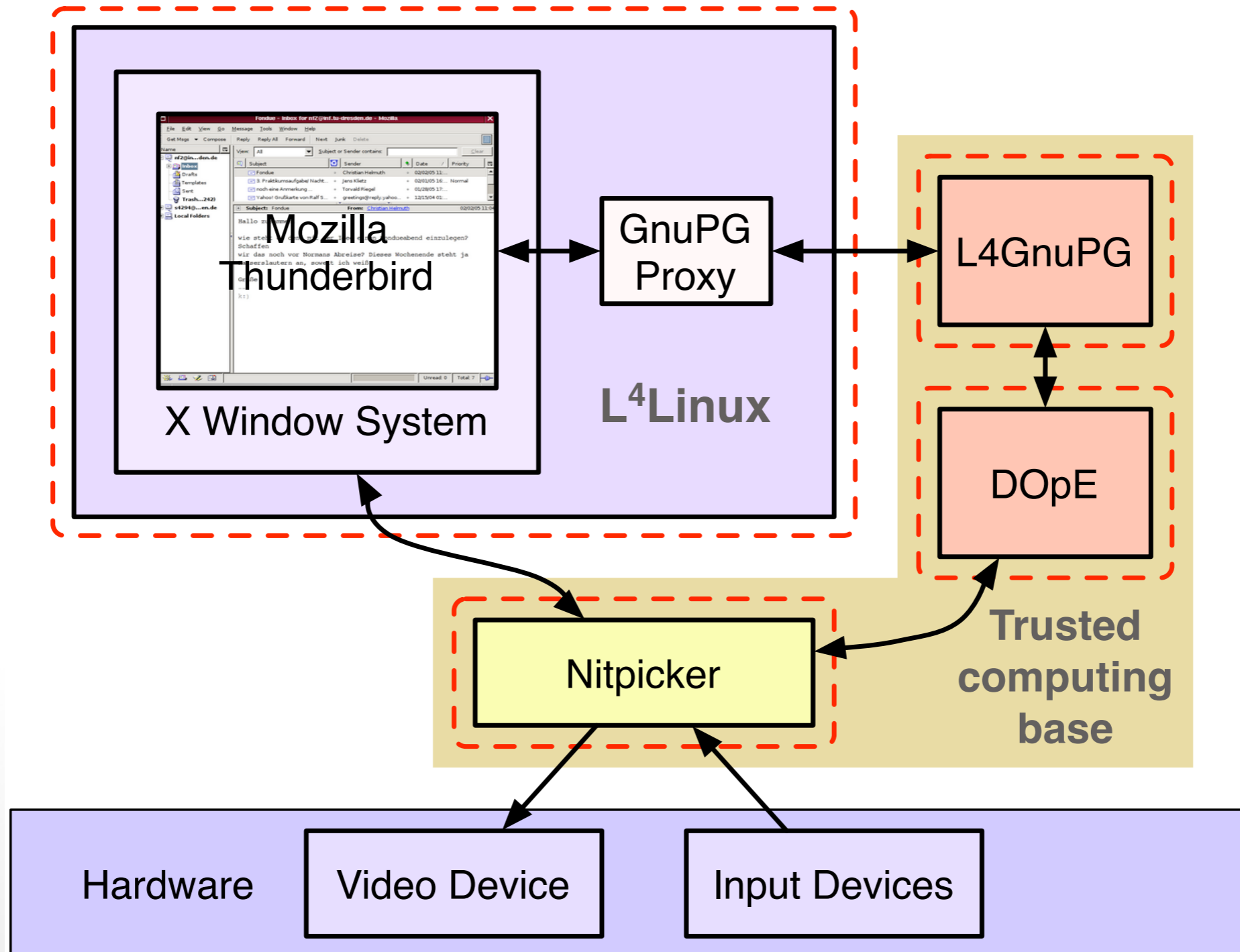

Image source: [5]

- *1,500,000+* SLOC no longer in TCB:
 - Linux kernel, drivers, X-Server
 - C and GUI libraries, Thunderbird, ...
- TCB size reduced to *~150,000* SLOC:
 - GNU Privacy Guard, e-mail viewer
 - Basic L4 system
- At least 10 times less code in TCB

- Splitting works for applications
- What about the complex and useful infrastructure of commodity OSes?
 - Drivers (see previous lectures)
 - Protocol stacks (e.g., TCP/IP)
 - File systems
- Starting point: Virtualized commodity OS

- Run legacy OS in VM
- Reuse service: net, files, ...
- Legacy infrastructure isolated from applications
- But:
 - Applications still depend on legacy services ... in TCB?
 - Interfaces reused, security issues as well?



- Network and file system stacks are virtually essential subsystems
- Generally well tested
- Ready for production use
- ... but not bug free [1,2]:
 - Linux file systems (UFS, ISO 9660, Ext3, SquashFS, ...): bug hunt of just 1 month yielded 14 exploitable flaws
 - WiFi drivers: remotely exploitable bugs

- Complex protocol stacks should not be part of TCB (for confidentiality + integrity)
- Reuse untrusted infrastructure through **Trusted Wrapper:**
 - Add security around existing APIs
 - Cryptography
 - Additional checks (may require copy of critical data, if original data cannot be trusted)
- General idea similar to TLS, VPN

VPN: Confidentiality, Integrity, ~~Availability~~

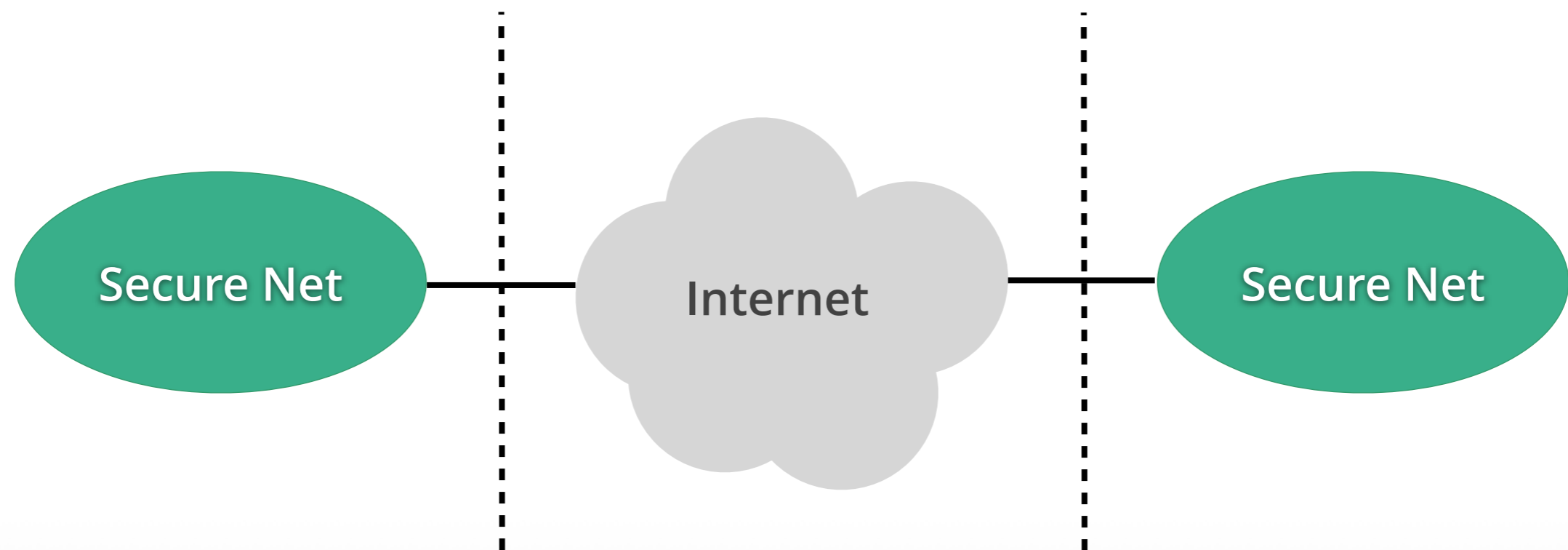

- SINA box used by German „BSI“:
- VPN gateway
- Implements IPSec & PKI
- Intrusion detection & response
- Used for secure access to government networks, e.g., in German embassies



Image source:
<http://www.secunet.com/de/das-unternehmen/presse/bilddatenbank/>

- Differently trusted network interfaces:
 - **Red:** plaintext, no protection
 - **Black:** encryption + authentication codes

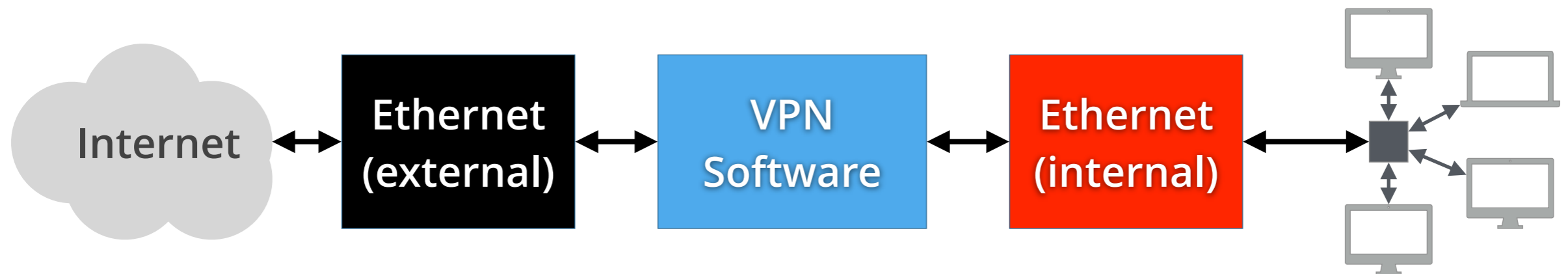

- VPN Software:
 - Based on minimized and hardened Linux
 - Runs only from read-only storage

- Linux is complex!
- SLOC for Linux 2.6.18:
 - Architecture specific: 817,880
 - x86 specific: 55,463
 - Drivers: 2,365,256
 - Common: 1,800,587
- Typical config: ~ 2,000,000
- Minimized & hardened: ~ 500,000

- Research project „Mikro-SINA“
- Goals:
 - Reduce TCB of VPN gateway software
 - Enable high-level evaluation for high assurance scenarios
 - Ensure confidentiality and integrity of sensitive data within the VPN
 - Exploit microkernel architecture

- Protocol suite for securing IP-based communication
- Authentication header (**AH**)
 - Integrity
 - Authentication
- Encapsulating Security Payload (**ESP**)
 - Confidentiality
- Key management / exchange

Application

TCP / UDP

IP

IPSec

Link Layer

- IPsec is security critical component
- ... but is integrated into Linux kernel

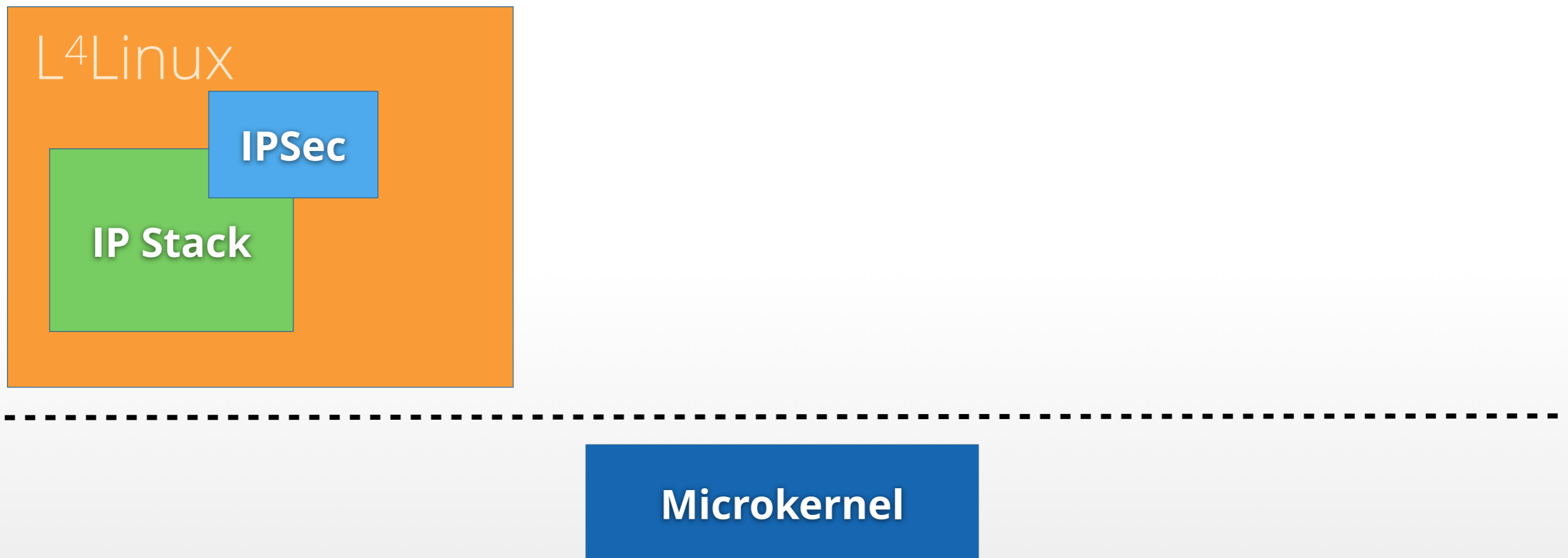

- **Idea:** Isolate IPsec in „Viaduct“
- IPsec packets sent/received through TUN/TAP device

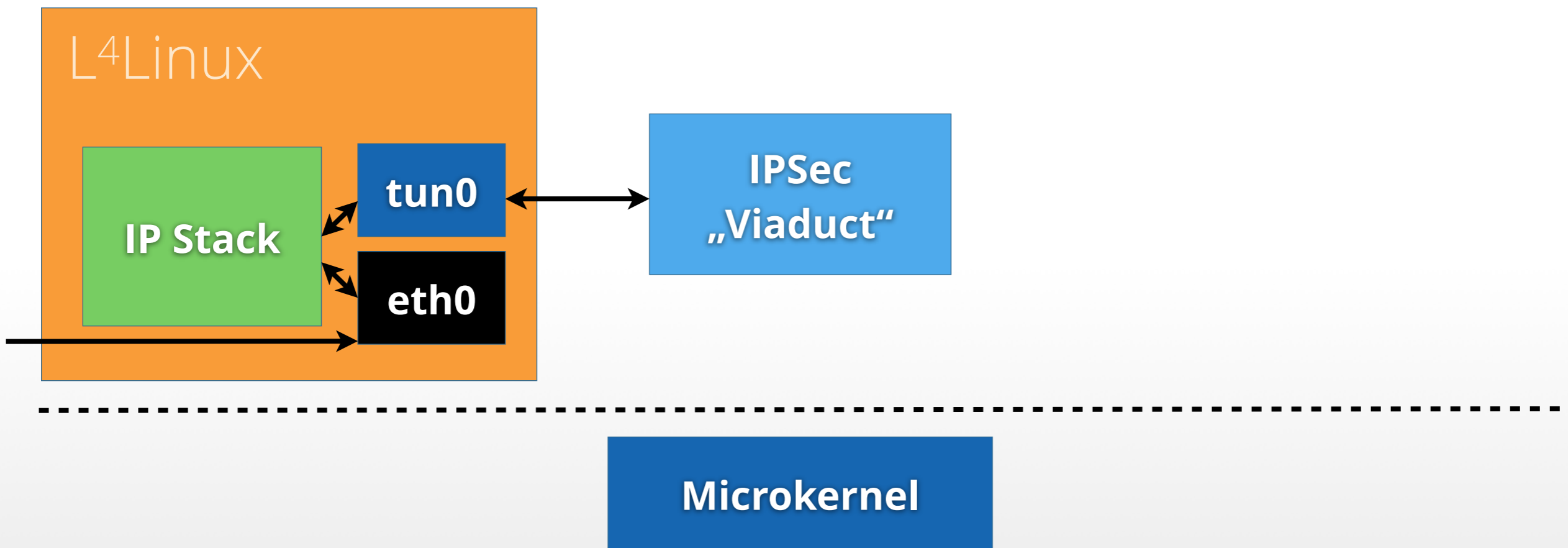

- Problem: Routers can fragment IPSec packets on the way
- Let L⁴Linux reassemble them

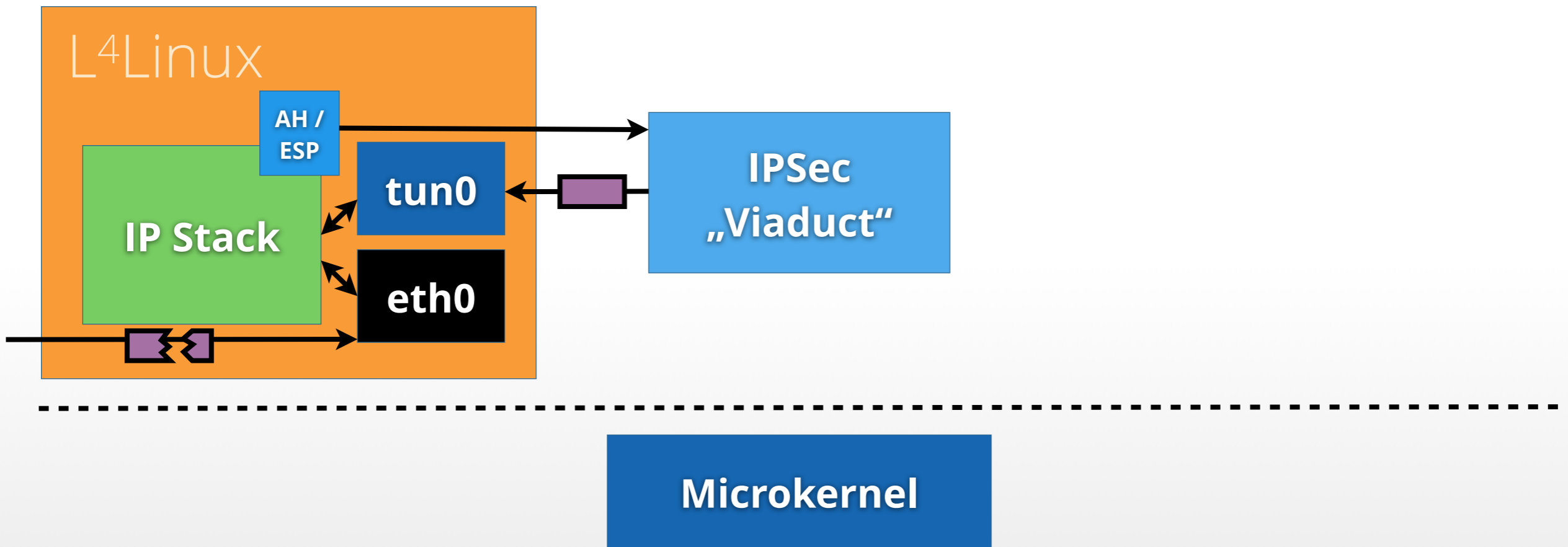

- Untrusted L⁴Linux instances must not see both plaintext and encrypted data
- Dedicated L⁴Linux for black/red networks

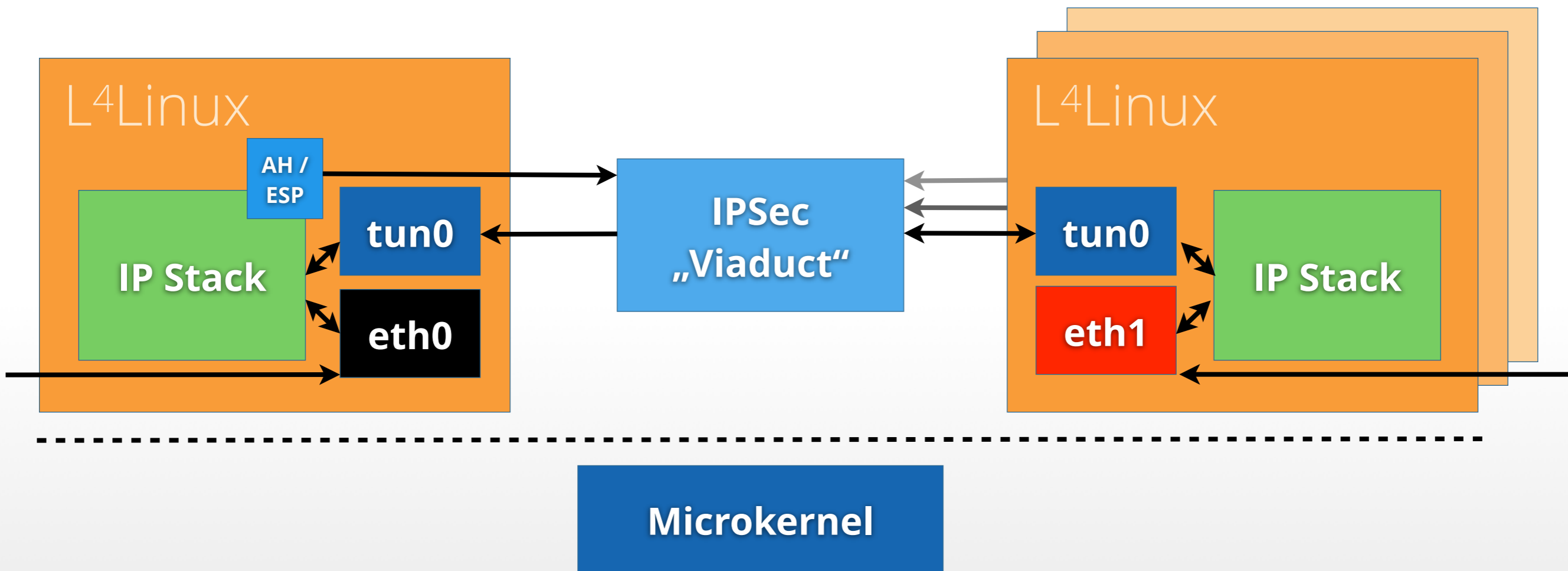

- Result: Trusted Wrapper for VPN
- Small TCB (see [6] for details):
 - 5,000 SLOC for „Viaduct“
 - Fine grain isolation
 - Principle of least privilege
- Extensive reuse of legacy code:
 - Drivers
 - IP stack

EXAMPLE 3: STORAGE

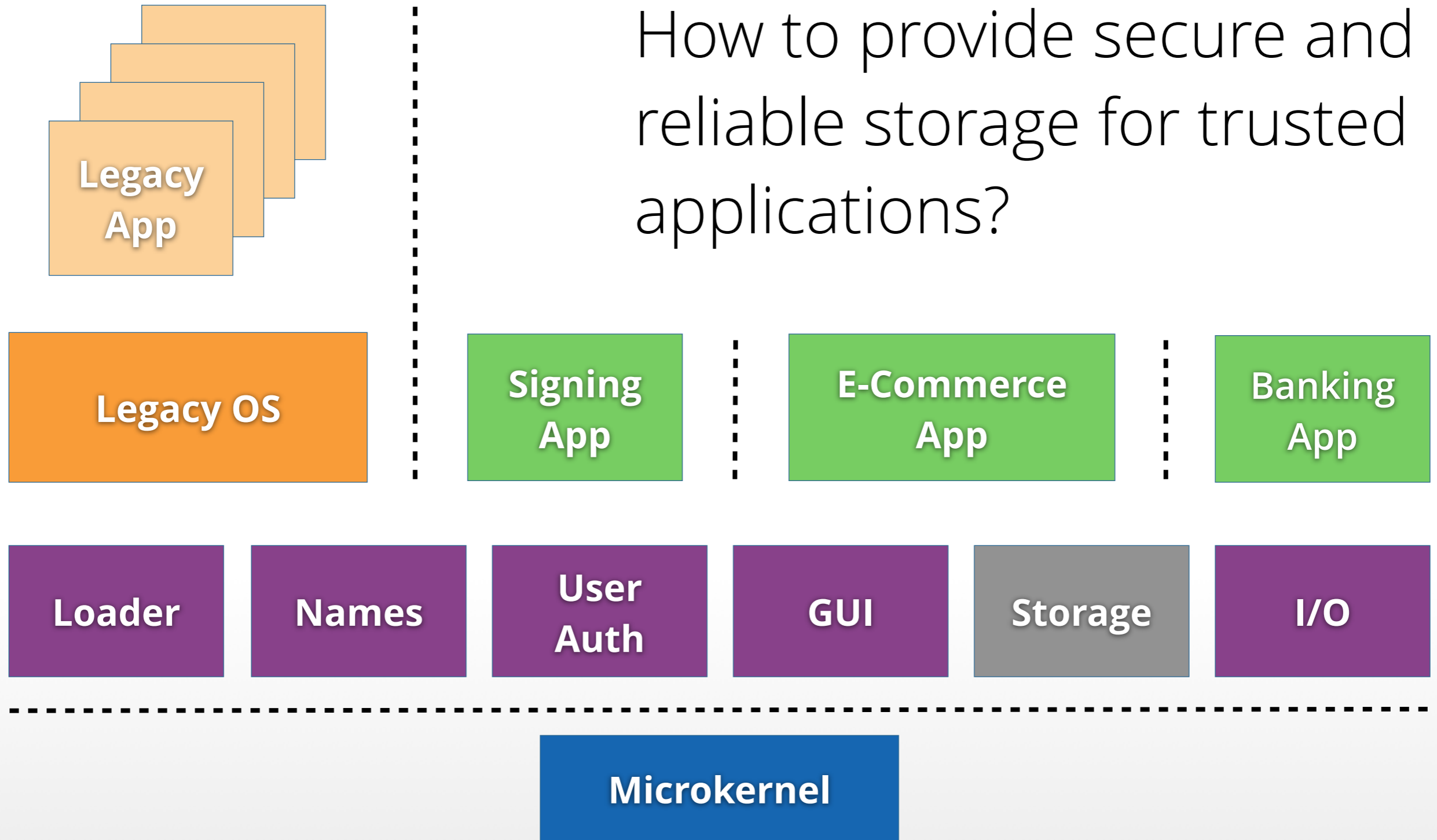

VPFS: Confidentiality, Integrity, ~~Availability~~

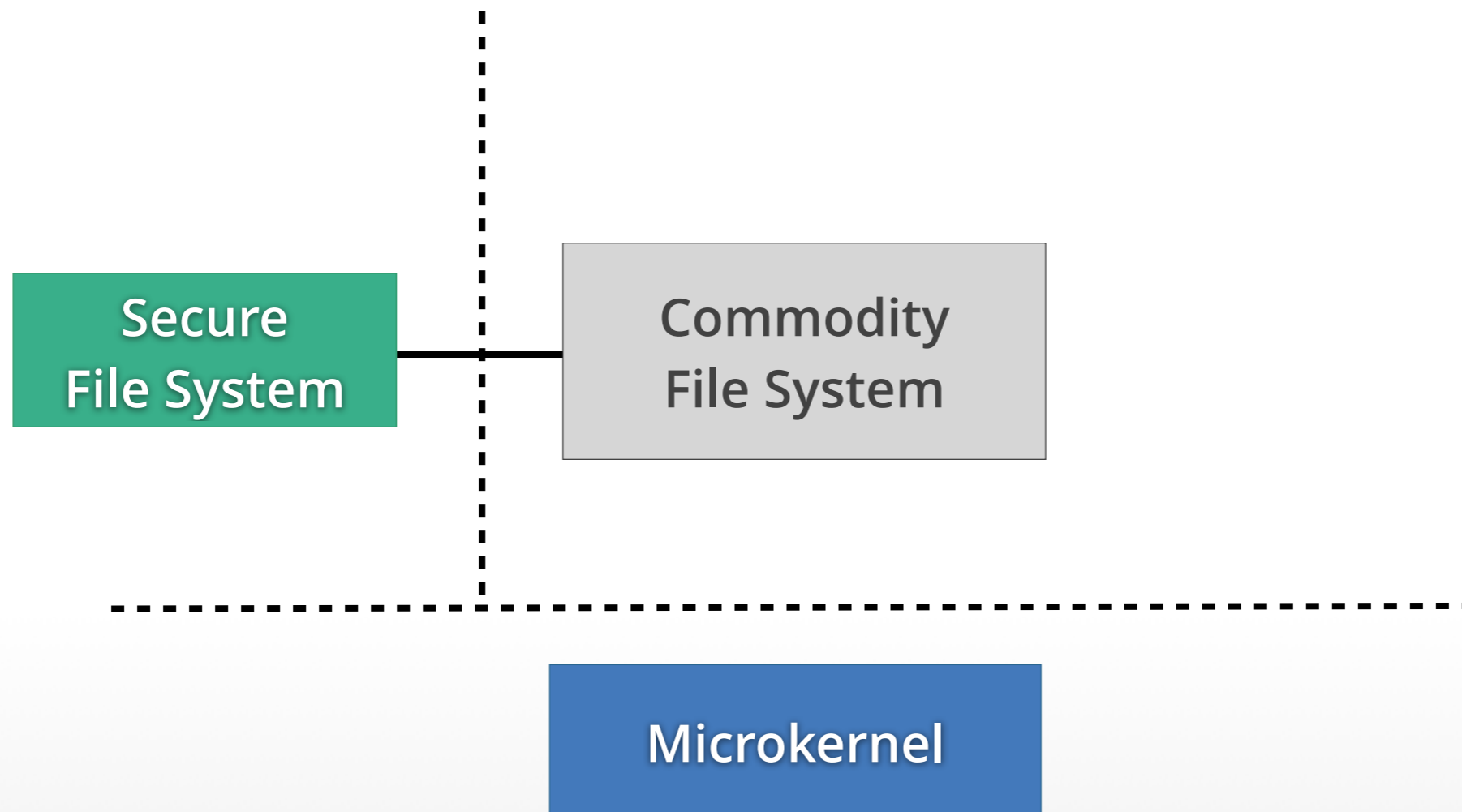

See [3] for details

VPFS: Confidentiality, Integrity, ~~Availability~~

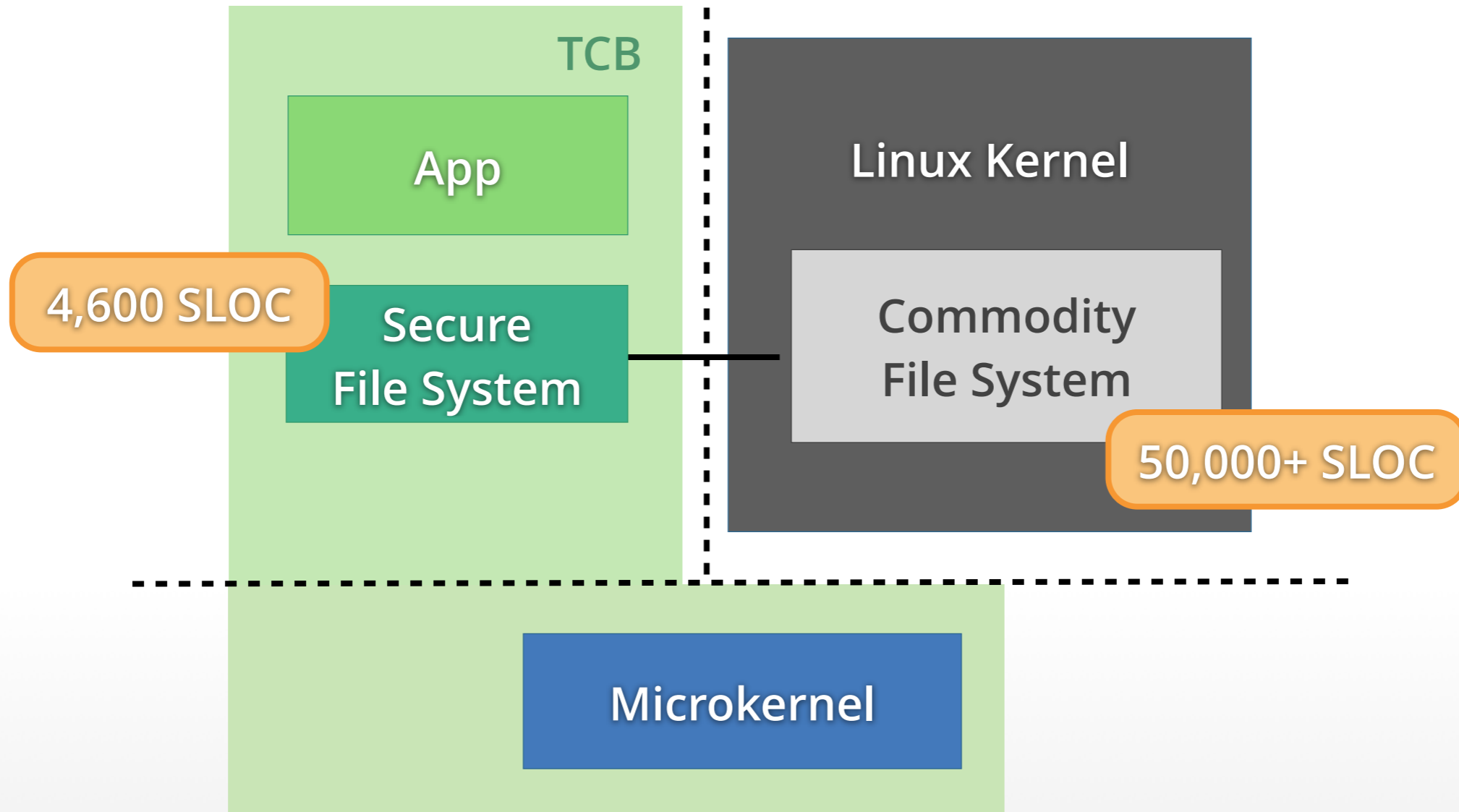

See [3] for details

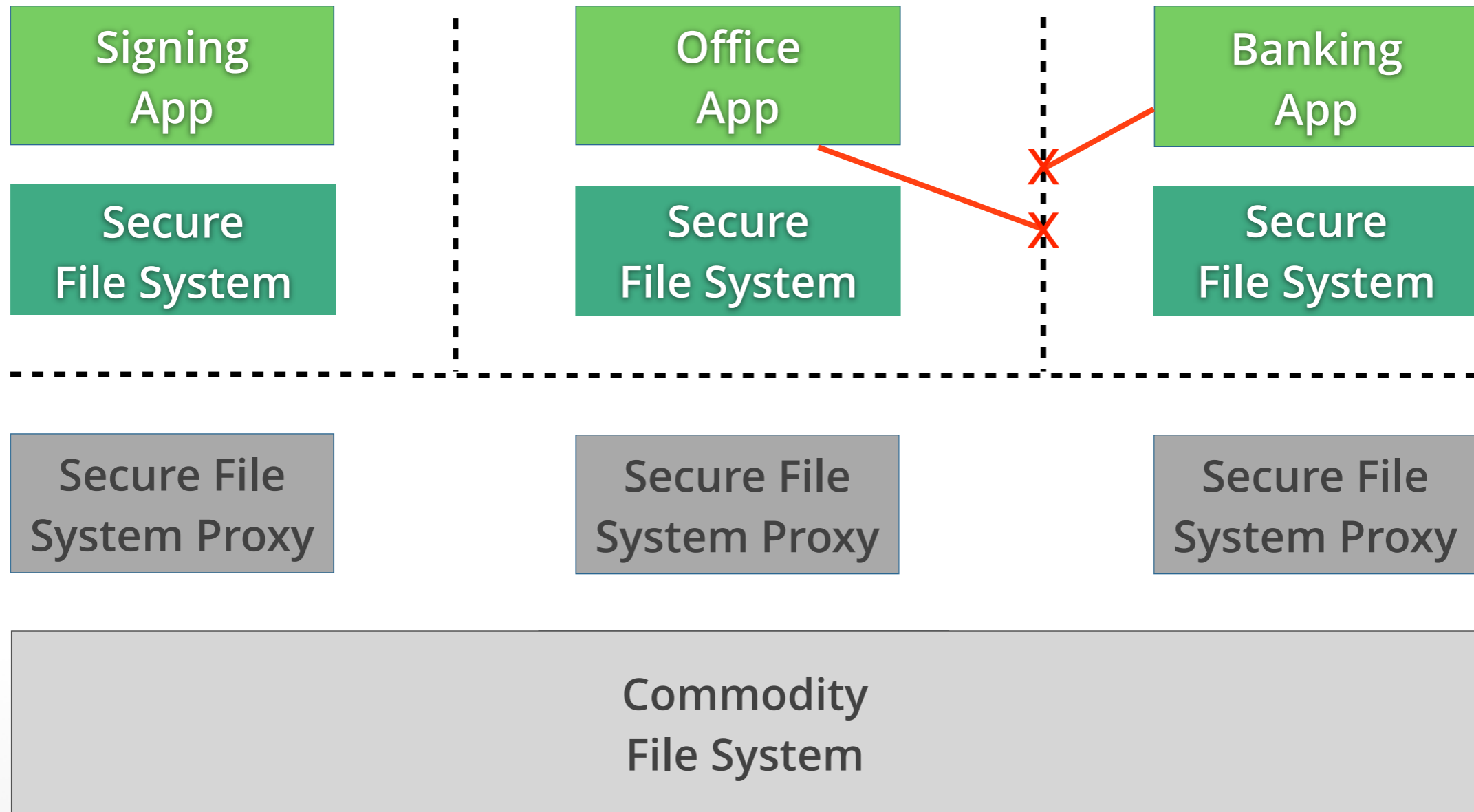

Isolate applications and their private storage: configure communication capabilities such that each application can access its private instance of the secure file system exclusively

- **Confidentiality:** only authorized applications can access file system, all untrusted software cannot get any useful information
- **Integrity:** all data and meta data is correct, complete, and up to date; otherwise report integrity error
- **Recoverability:** damaged data in untrusted file system can be recovered

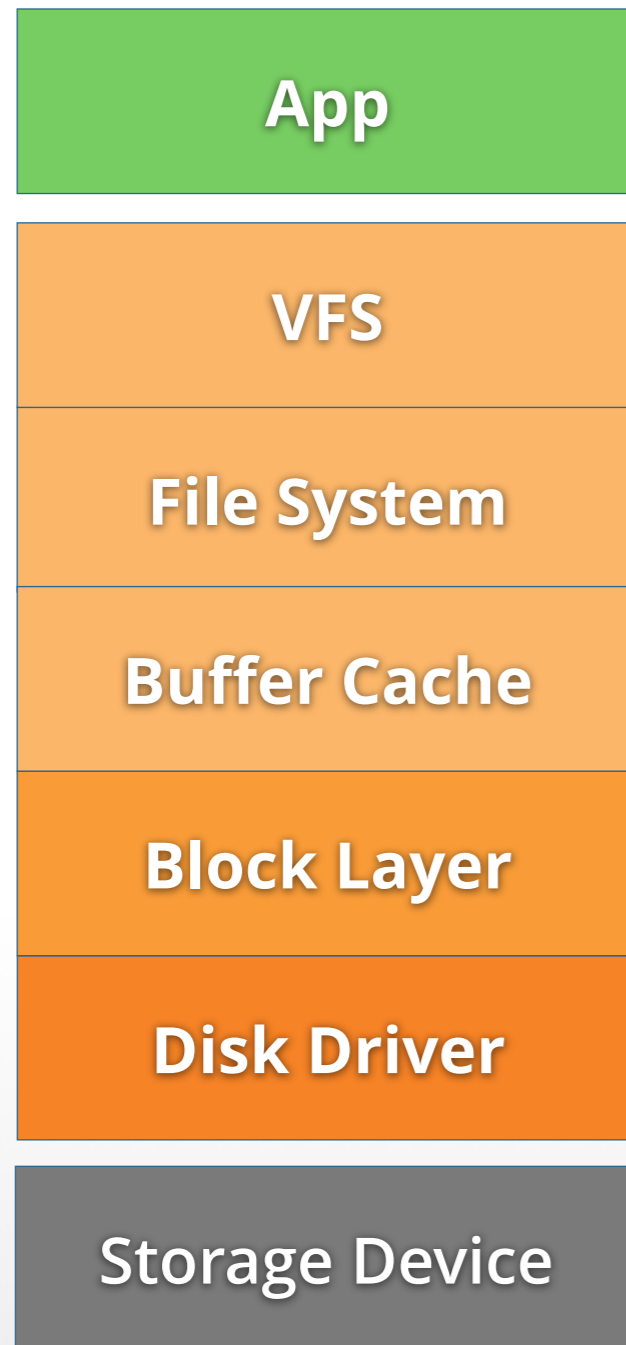

File-level protection

- CFS** Cryptographic File System for UNIX
- EFS** Microsoft Encrypting File System
- ecryptfs** Linux kernel support + tools
- EncFS** Based on FUSE

Volume-level protection

- TrueCrypt, Filevault 2**
- dm_crypt**
- Bitlocker**
- Encrypted volumes in smartphones, etc.

- First end of design space:
Protect at block layer
- Transparent encryption of all
data and metadata
- Block-level integrity ???
- Most parts of file system stack
are part of TCB
- Attack surface still big

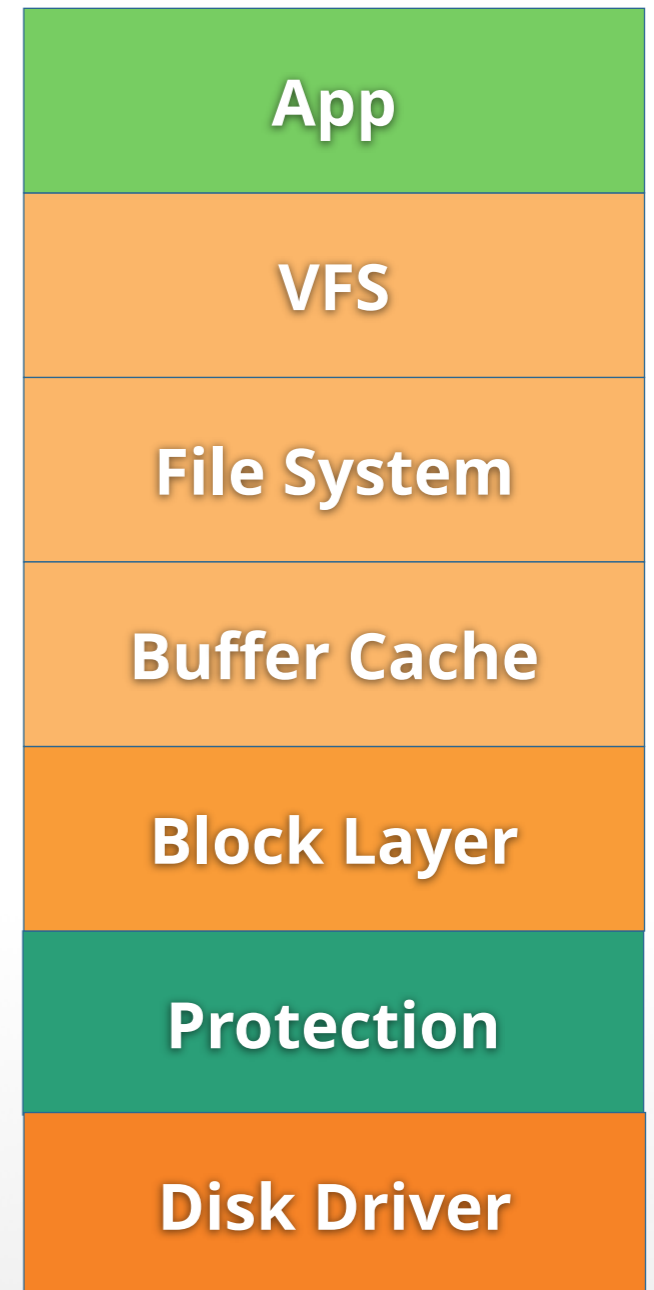

- Second end of design space:
Protect individual files
 - Stacked file system
 - Encrypt all data and some metadata (directories, ...)
 - More flexibility for integrity
 - Most parts of file system stack not part of TCB
 - Ideal for trusted wrapper

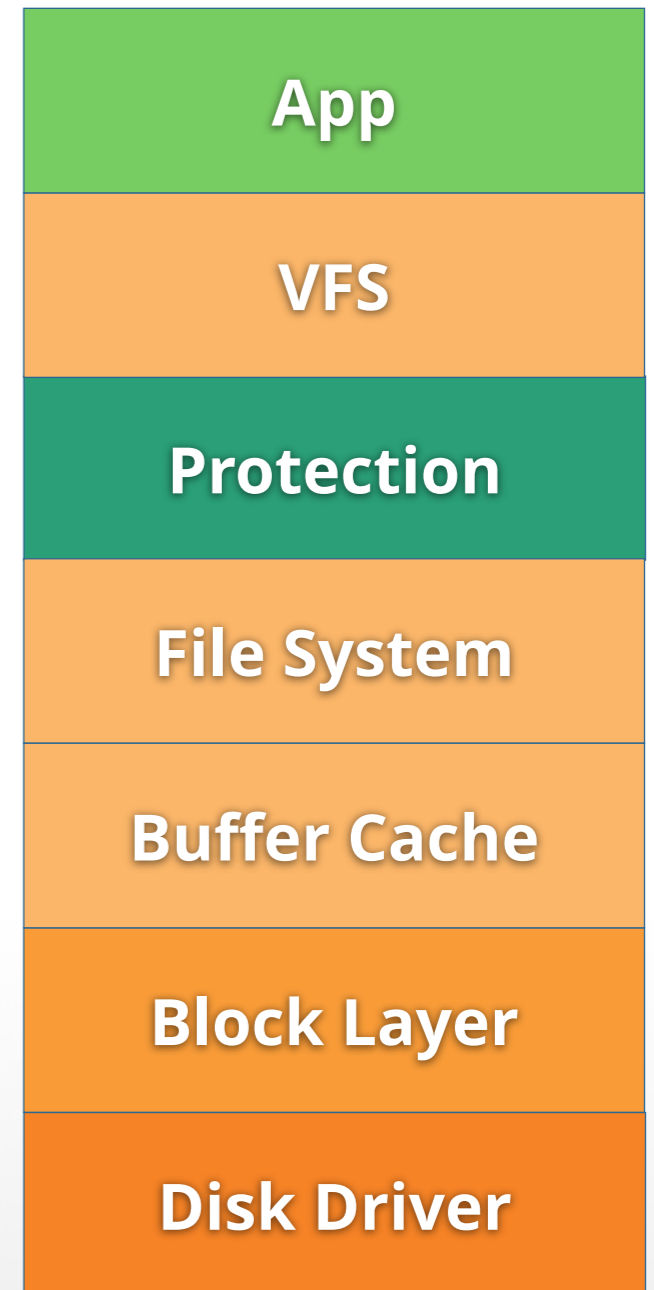

TRUSTED WRAPPER

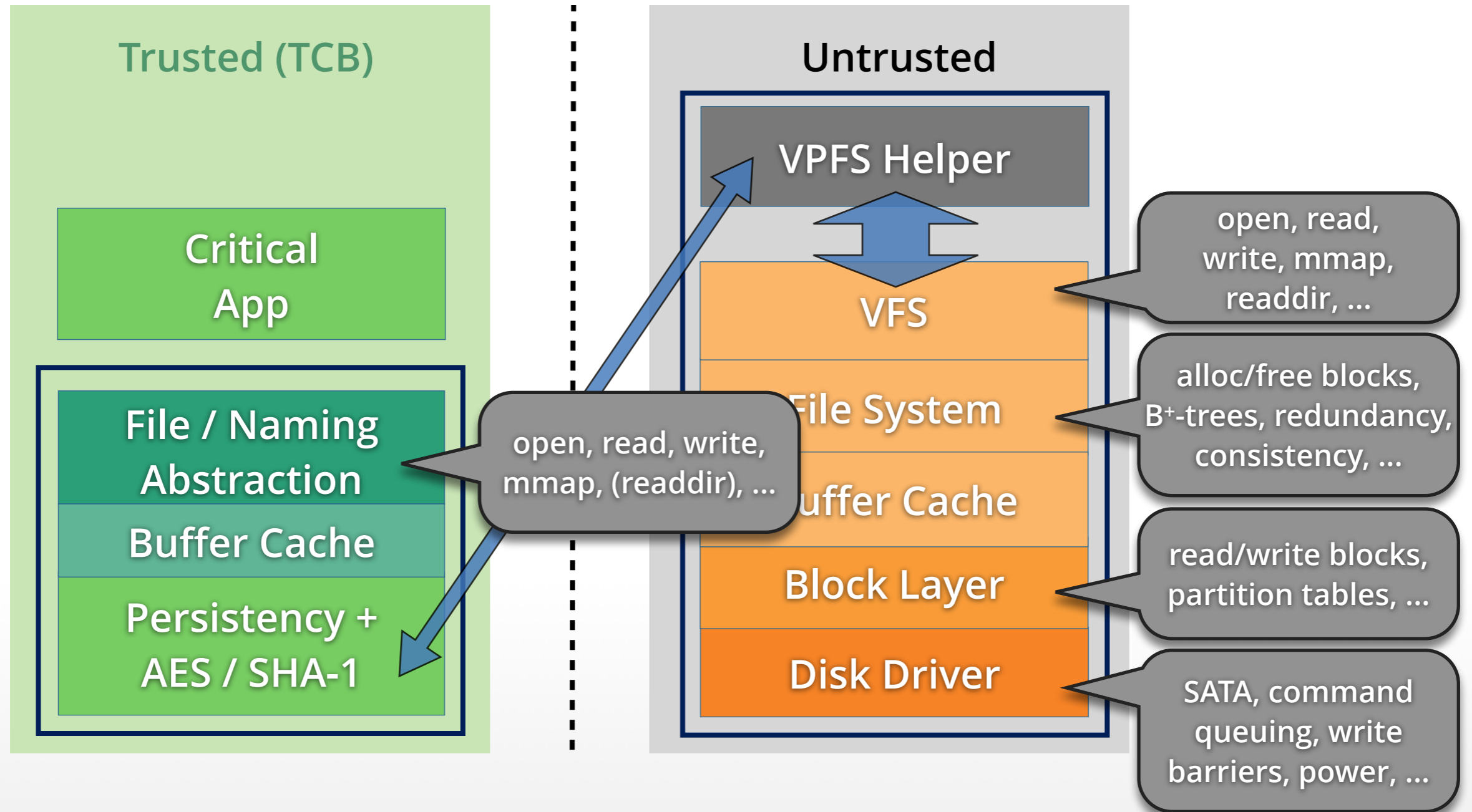

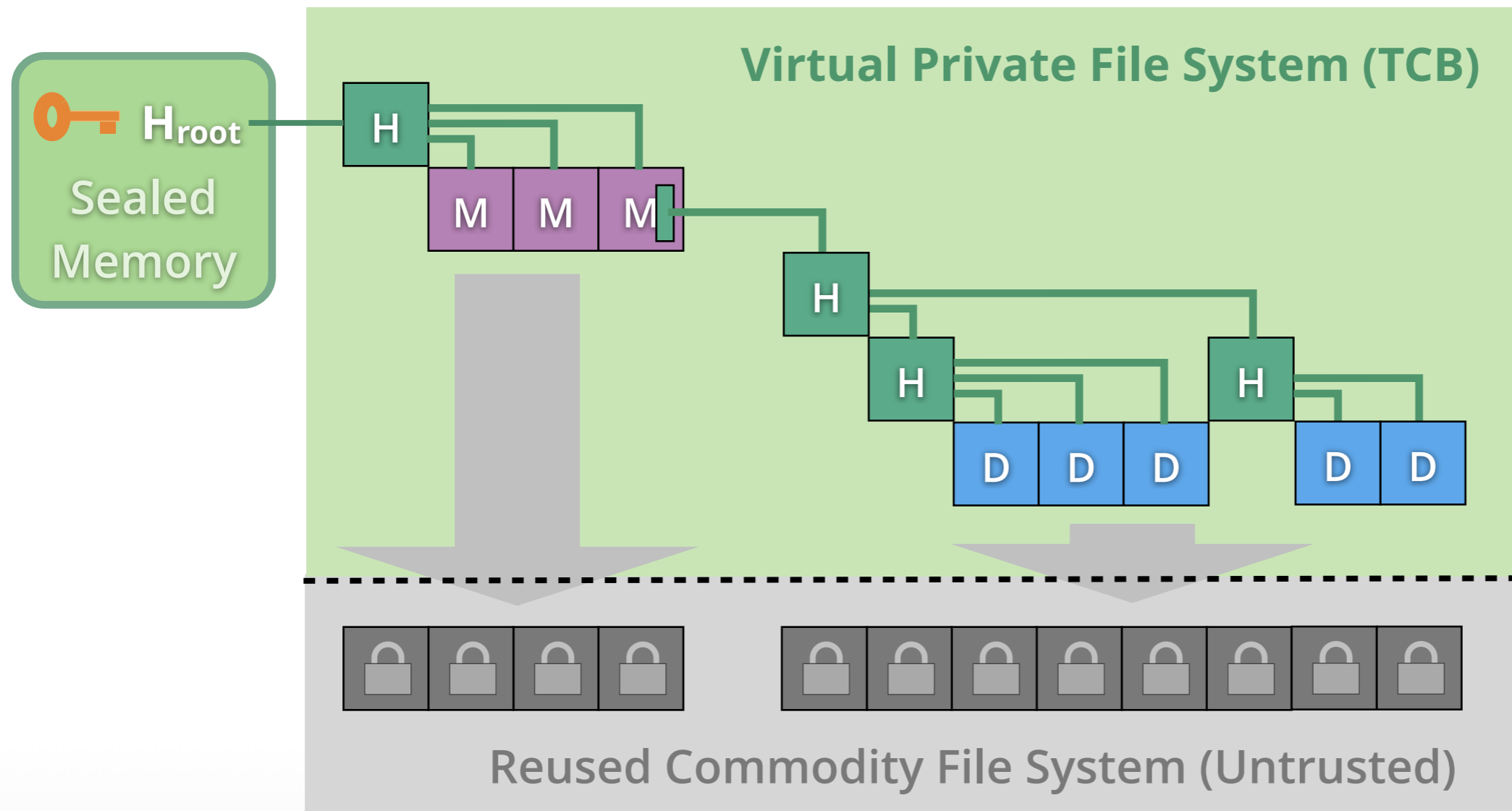

- Encrypted files in commodity file system
- Merkle **hash tree** to detect tampering

- Trusted part of VPFS enforces security:
 - Encryption / decryption on the fly
 - Plaintext only in trusted buffer cache
 - Files in untrusted commodity file system store encrypted blocks
 - Hash tree protects integrity of complete file system
 - Single hash of root node stored securely

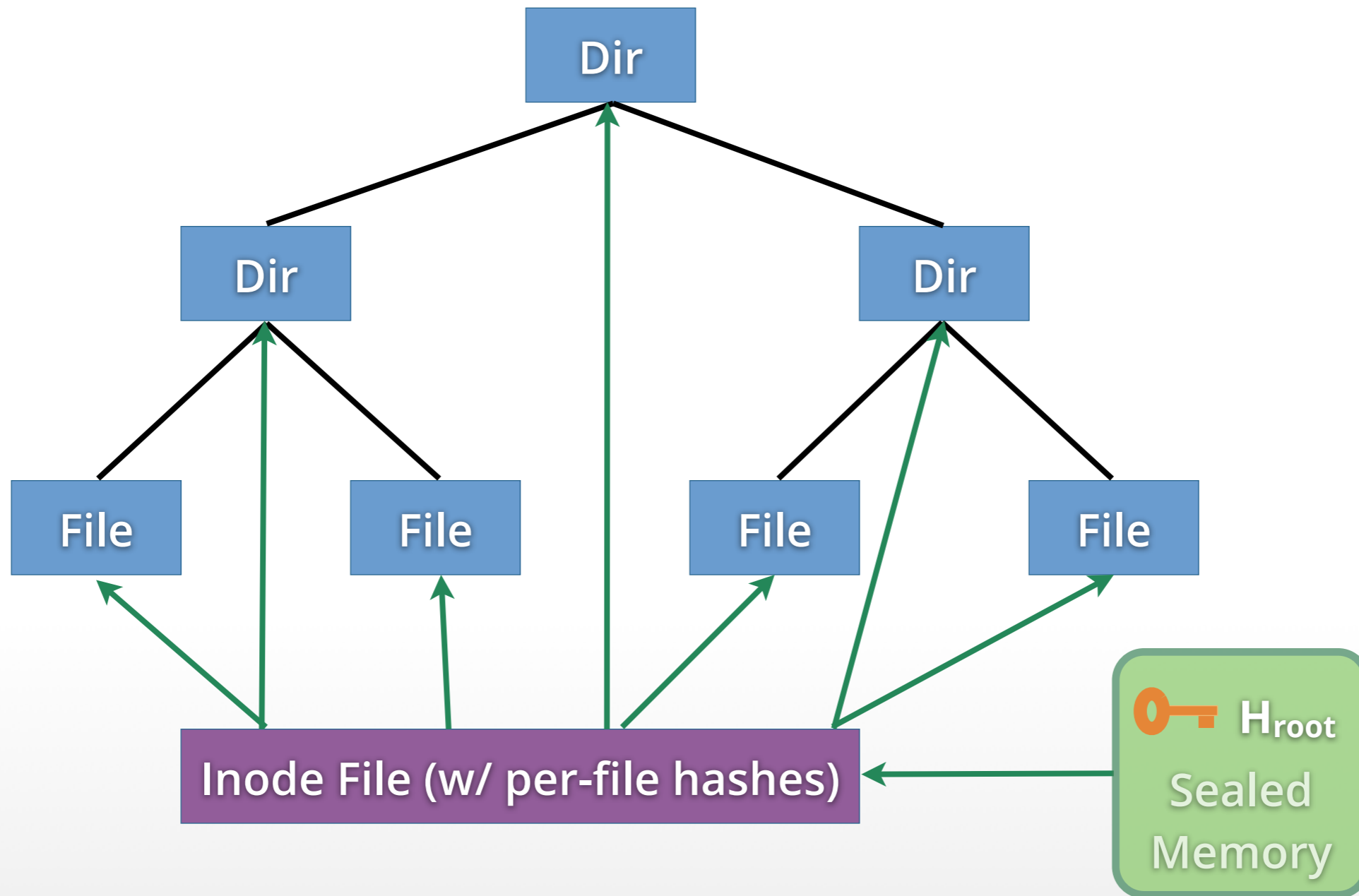

- VPFS reuses Linux file system stack:
 - Drivers, block device layer
 - Optimizations (buffer cache, read ahead, write batching, ...)
 - Allocate / free disk storage for files
- Cooperation: proxy driver in L⁴Linux

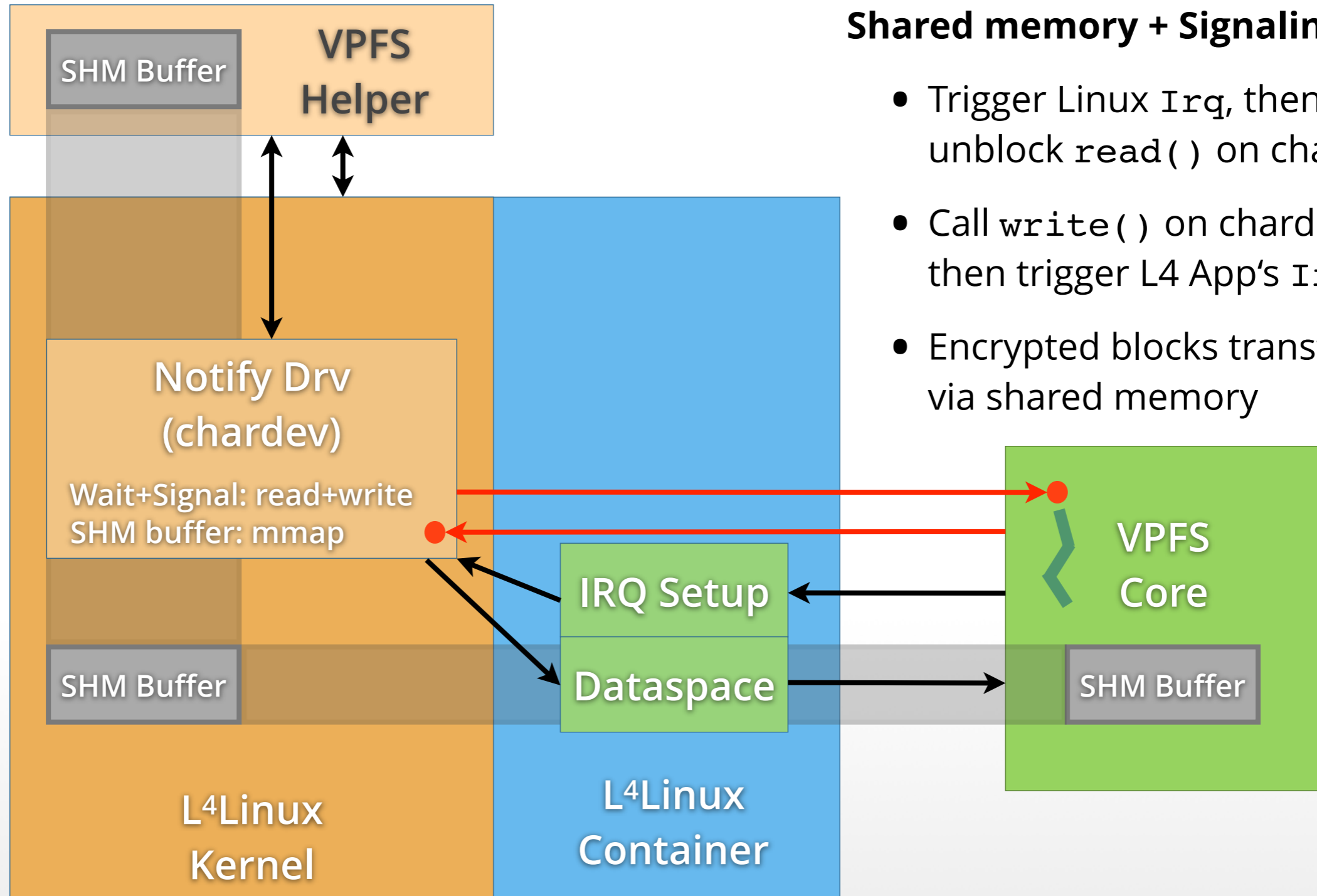

Shared memory + Signaling:

- Trigger Linux Irq, then unblock `read()` on chardev
- Call `write()` on chardev, then trigger L4 App's Irq
- Encrypted blocks transferred via shared memory

- Trusted wrappers for file systems work!
- VPFS is general purpose file system
- Significant reduction in code size:
 - Untrusted Linux file system stack comprises **50,000+** SLOC
 - VPFS adds **4,000** to **4,600** SLOC to application TCB [3]
 - jVPFS adds another **350** SLOC for secure journaling to protect against crashes [4]

- Secure reuse of untrusted legacy infrastructure
- Split apps + OS services for smaller TCB
- Nizza secure system architecture:
 - Strong isolation
 - Application-specific TCBs
 - Legacy Reuse
 - Trusted Wrapper

BRIEFLY: HARDWARE ISOLATION

APPLE SECURE ENCLAVE

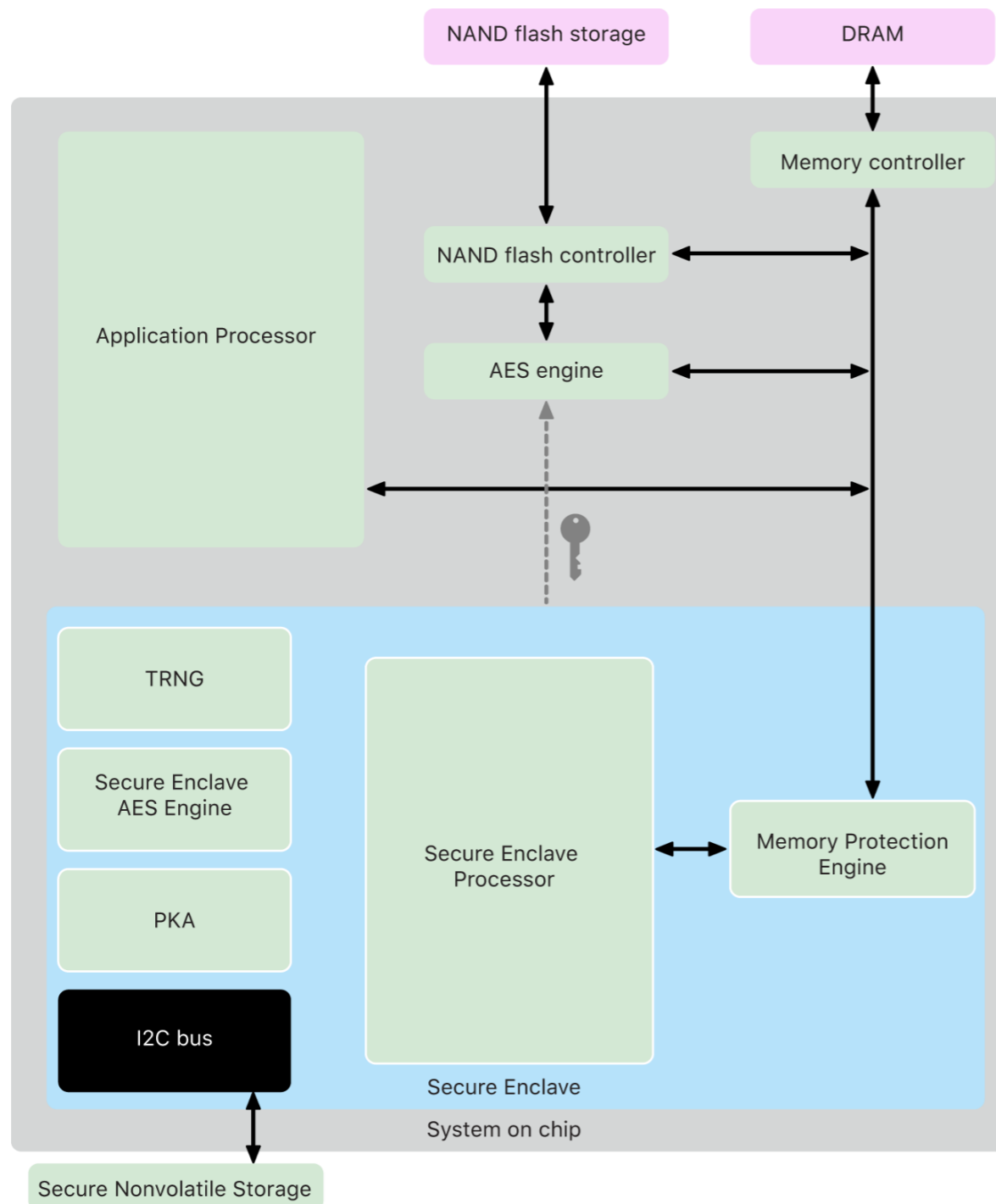

Apple devices have "Secure Enclave Processor (SEP)" running a dedicated service OS fully isolated from from the application processor hardware.

The SEP runs sepOS:

"The Secure Enclave firmware is based on a version of the L4 microkernel customized by Apple."

Source: Apple Support Documentation
<https://support.apple.com/guide/security/secure-enclave-sec59b0b31ff/web>

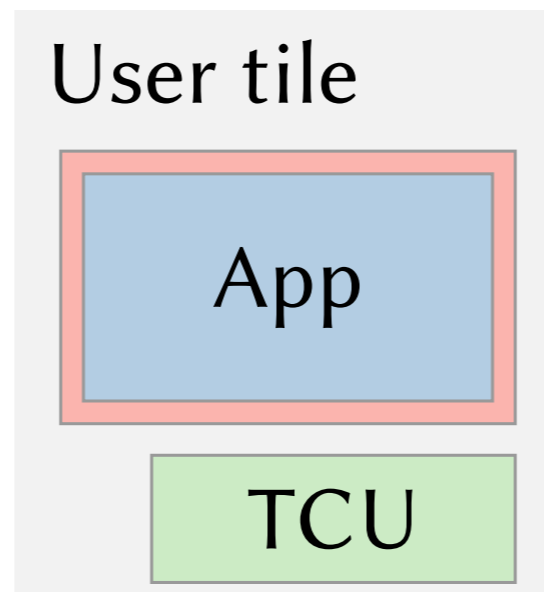
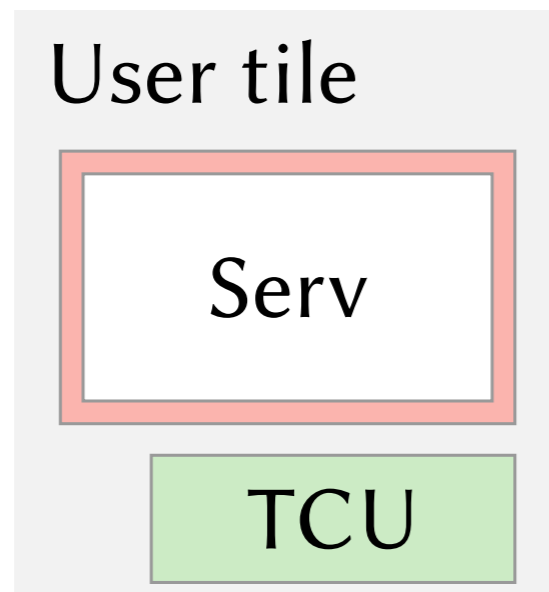
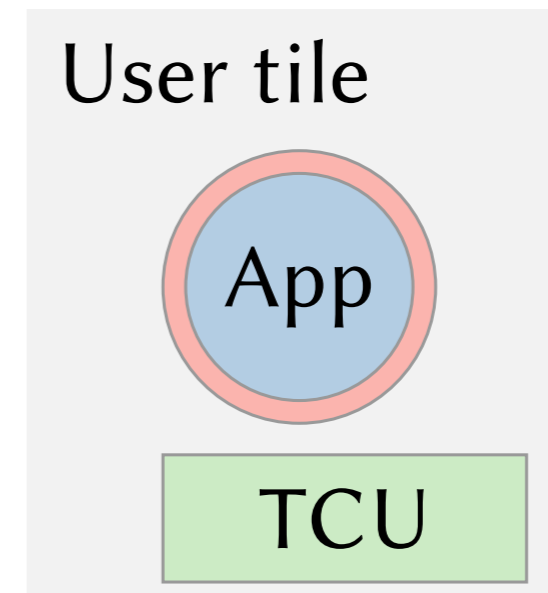
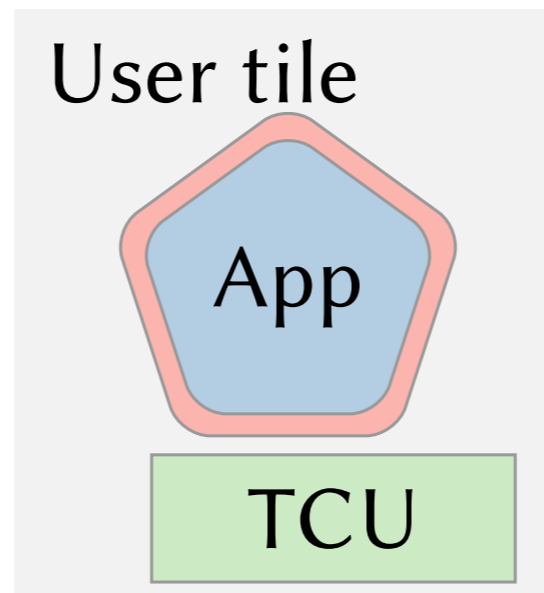
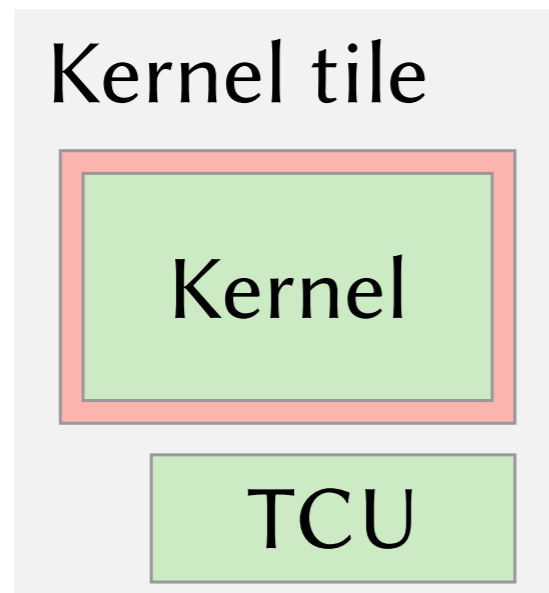

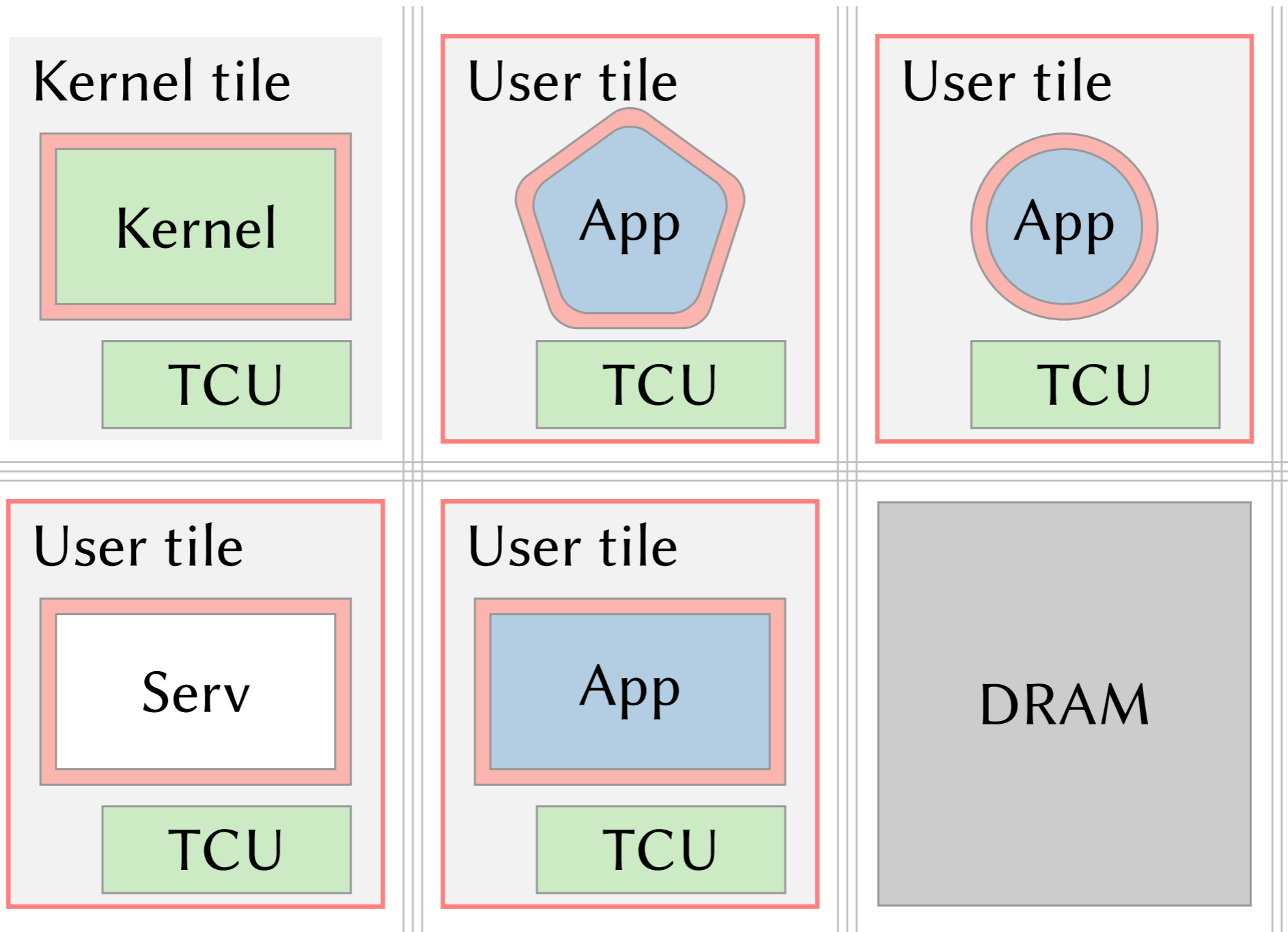

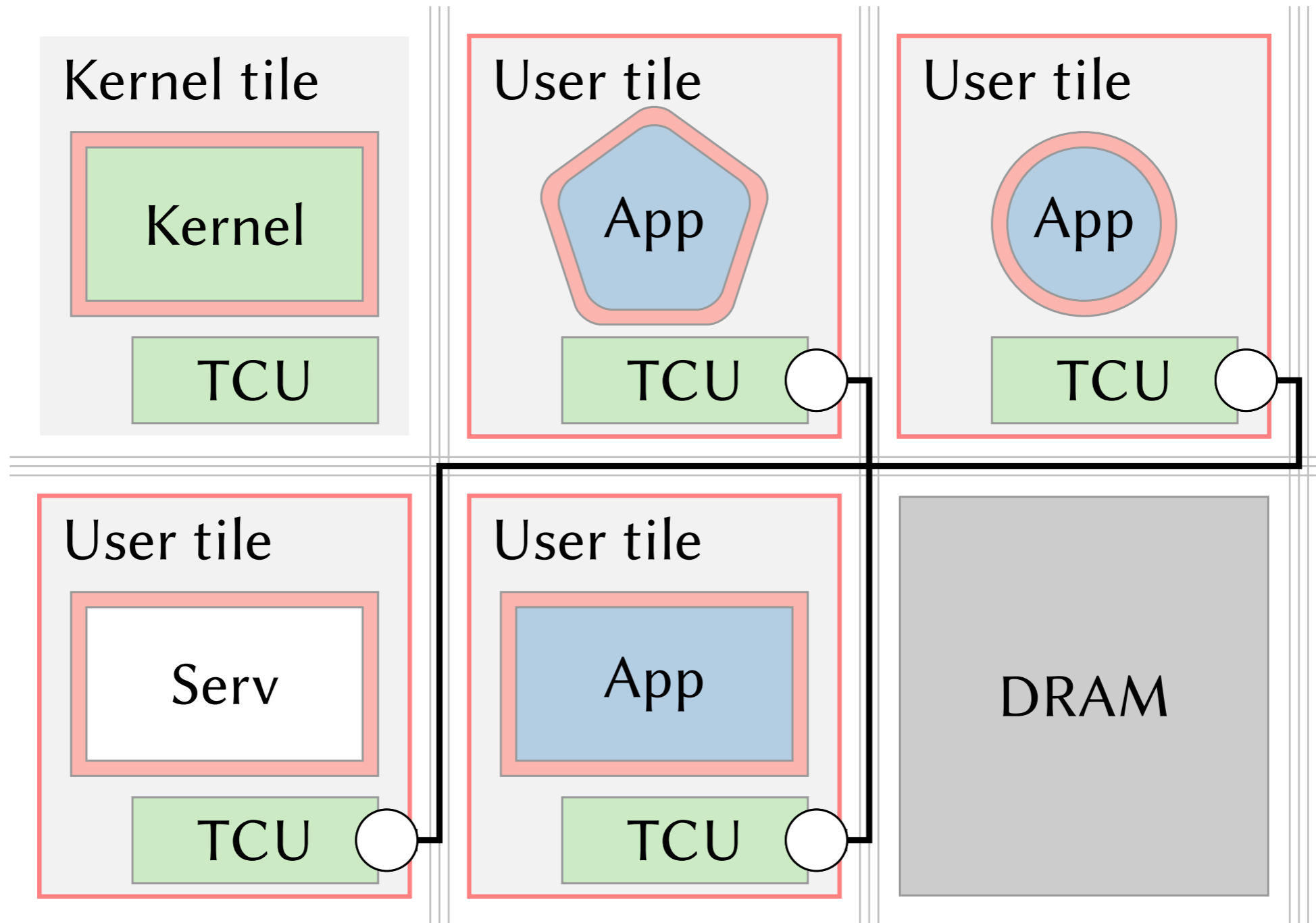

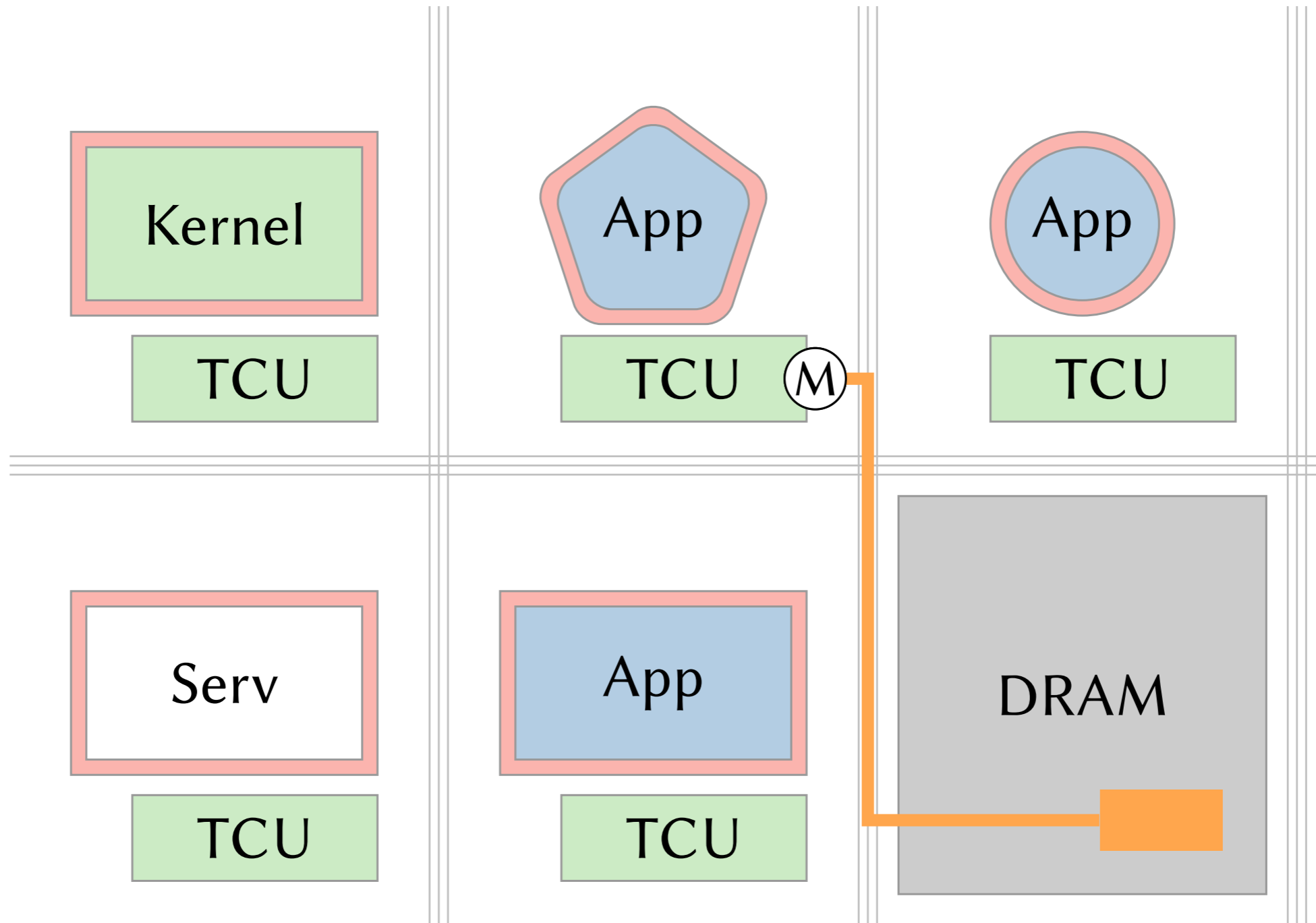

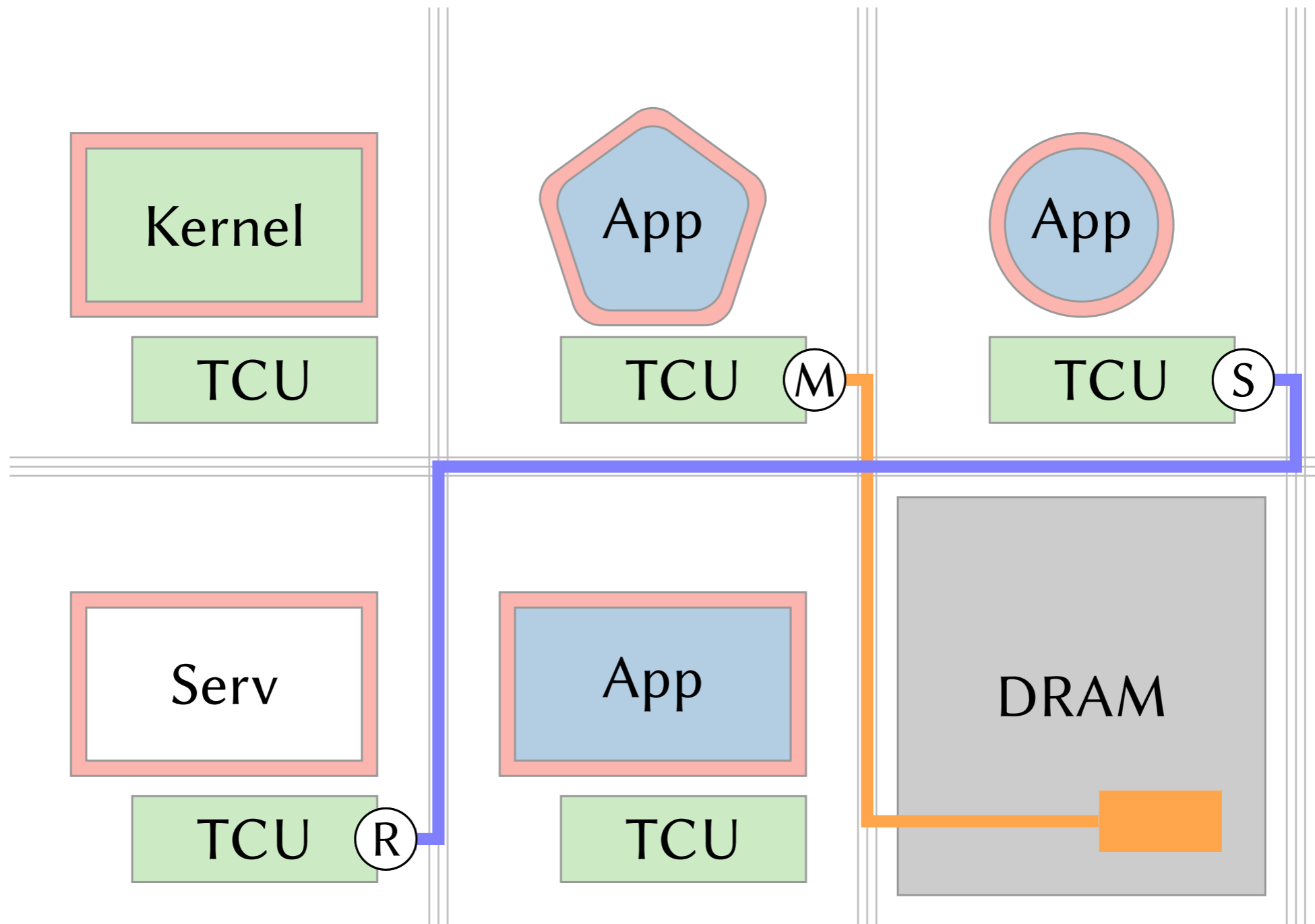

- [1] <http://www.heise.de/newsticker/Month-of-Kernel-Bugs-Ein-Zwischenstand--/meldung/81454>
- [2] <http://projects.info-pull.com/mokb/>
- [3] Carsten Weinhold and Hermann Härtig, „VPFS: Building a Virtual Private File System with a Small Trusted Computing Base“, Proceedings of the 3rd ACM SIGOPS/EuroSys European Conference on Computer Systems, April 2008, Glasgow, Scotland UK
- [4] Carsten Weinhold and Hermann Härtig, „jVPFS: Adding Robustness to a Secure Stacked File System with Untrusted Local Storage Components“, Proceedings of the 2011 USENIX Annual Technical Conference, Portland, OR, USA, June 2011
- [5] Norman Feske and Christian Helmuth, „A Nitpicker's guide to a minimal-complexity secure GUI“, ACSAC '05: Proceedings of the 21st Annual Computer Security Applications Conference, 2005, Washington, DC, USA
- [6] Christian Helmuth, Alexander Warg, Norman Feske, „Mikro-SINA - Hands-on Experiences with the Nizza Security Architecture“, D.A.CH Security 2005, 2005, Darmstadt, Germany
- [7] <http://support.apple.com/kb/HT4013>
- [8] <http://support.apple.com/kb/HT3754>
- [9] <http://jailbreakme.com>
- [10] Asmussen et al.: „M3: A Hardware/OS Co-Design to Tame Heterogeneous Manycores“, ASPLOS'16